

**EQUIP - DIET KASARAGOD**  
**SSLC QUESTION POOL**  
**PHYSICS - ENGLISH MEDIUM**

---

**1 Mark Questions**

1. Find the odd one from the group. Give Reason.  
(Coke, Coal tar, Peat, Coal gas)
2. What is the reason for the dispersion of light.  
(Scattering, Refraction, Reflection)
3. In our country AC generated in .....voltage.
4. Name the mirror which is used as rear view mirror.
5. Which lens always form small, diminished and virtual image.
6. Moving coil loud speaker is working under ..... principle
7. Which one of the following is not a quality of the LED lamps?
  - Not harmful to the environment
  - High efficiency
  - Loss of energy in the form of heat
  - High longevity.
8. Biogas : Methane    LPG : .....
9. If speed of light in one medium is  $2 \times 10^8 \text{m/s}$ , what is the refractive index of that medium? (Speed of light in air is  $3 \times 10^8 \text{m/s}$ )
10. Find the relation and complete the word pair?  
Electric bulb : Lighting effect ; soldering iron : .....
11. Write the Energy change in electric motor.....
12. What is the frequency of AC generated in India?
13. If radius of curvature of a mirror is 48cm. Then find the focal length of that mirror?

14. If the refracted ray is passing parallel to the surface of separation of two medium, then what is the angle of refraction?

15. Find the odd one and give reason.

(Solar energy, fossil fuel, geo thermal energy, wave energy)

16. In which colour does Newton's colour disc appear when rotated fast?

What property of the eye makes this possible?

17. If size of the image formed by convex lens as same as the size of the object, then what is the magnification?

(+1, -2, -1, +2)

18. Which part of the appliance is connected to the pin E of the three pin plug?

19. Which of the following is incorrect?

$$\left( P = IR^2, P = VI, P = \frac{V^2}{R}, P = I^2R \right)$$

20. From the following which one is not a part of dc motor?

(Armature, Field magnet, Voice coil, Splitring)

21. Safety fuse works on heating effect of electric current. To which line the fuse is connected?

22. When white light passes through a prism it undergoes dispersion. Which colour deviate more and which colour deviate least?

23. LPG is a colourless odourless gas. Which chemical substance is added for the smell?

24. Which defect of vision can be rectified by using concave lens.

(Near sightedness, Longsightedness, Presbyopia)

25. Which device is used to bring changes in electric current without loss of power?

(Resistor, Ammeter, Voltmeter, Inductor)

26. Hydrogen has the more calorific value. What you mean by Calorific value?

27. For a normal vision of human being near point is ..... and far point is .....

28. When electric current through a circuit is reduced to half then,  
Heat produced is ..... times according to Joule's Law.  
(4, 2,  $\frac{1}{4}$ ,  $\frac{1}{2}$ )
29. Select the wrong statement related to Tungsten filament?  
 \ a) High Resistivity  
 b) High ductility  
 c) Low melting point  
 d) It can be kept white hot
30. Write the correct relation  
Transformer : Mutual Induction : : Generator : .....
31. Identify the position of object when a convex lens produce real and enlarged image.  
(At 2F, Between F and lens, Beyond 2F, Between F and 2F)
32. Can you guess why red colour has been given to Danger Signals?
33. The full form of LPG is .....
34. Total number of images formed when two plane mirrors are arranged at  $120^\circ$   
(2, 1, 3, 4)
35. What is Biomass?
36. How are the Electrical appliances are connected in House hold circuits?
37. Find the correct relation and fill in the blanks.  
Heat : Joule : : Resistance : .....
38. What are the reason for excess current flow through the curcuits?
39. Most abundant fossil fuel on earth is .....
40. Find power of a convex lens of focal length 50cm?  
(+4D, +2D, +5D, +3D)
41. Locate the position of object in order to get virtual, erect and enlarge image when it is kept infront of a concave mirror at,  
(between F and P, Beyond C, At C, Between C and F)

42. Potential difference between 2 phase line is
43. Give a situation in which we can use only solar panels?
44. Find height of image, when an object of height 4 cm, is placed in front of a convex lens of magnification - 2.
45. According to Flemings Left Hand Rule, Fore finger indicate direction of magnetic field, middle finger indicate the direction of....., and thumb indicate the direction of .....

### 2 Marks Questions

46. Ten  $3\Omega$  resistors are connected in parallel manner. Find the effective resistance of the combination?
47. What is photovoltaic effect ?
48. How does the earth pin differs from the other pins ?
49. What are the factors influence the magnetic field of a current carrying Solenoid?
50. Raindrops falling down during rain appear like a glass rod. Explain the phenomenon?
51. Calorific value of a fuel marks as  $45000\text{KJ/kg}$ " What does it mean? Write any two characteristics of a good fuel?
52. Solenoid of same length and thickness are connected to points A and B in the 2 circuits. Observe the circuits and answer the following questions.

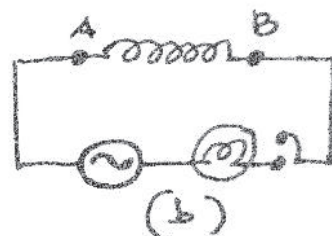
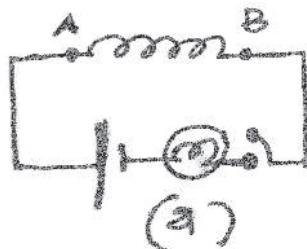

- (i) When circuit (a) and (b) are switched ON what changes do you observe in the intensity of light?
- (ii) Give its reason?

53. What is the reason for twinkling of star? Explain the phenomenon?

54.

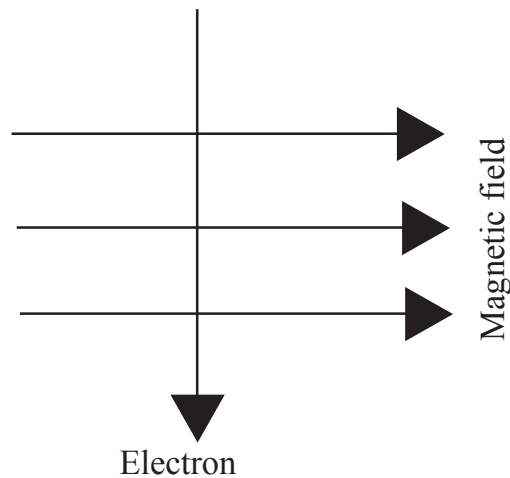

The direction of movement of electrons through a magnetic field is depicted. Find the direction of force felt by electrons? Explain the law use to find the direction of force.

55. Select the correct statements from the following.

- (i) Magnification is negative when the image is Virtual and Erect.
- (ii) If magnification is greater than one then size of image is greater than object.
- (iii) If magnification is one then size of image and object are same.
- (iv) If magnification is positive, then image is inverted and real.

56. What is the advantage of discharge lamp over incandescent lamp?

57. When a pencil is placed in a glass of water, what change you can observe?

Explain the phenomenon behind it?

58. Complete the path of rays in fig (a) and (b)

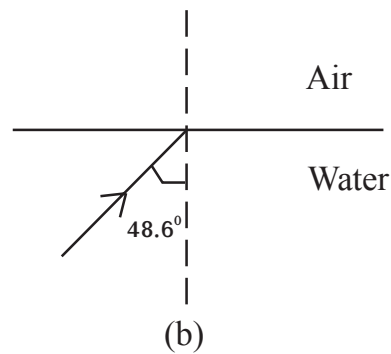
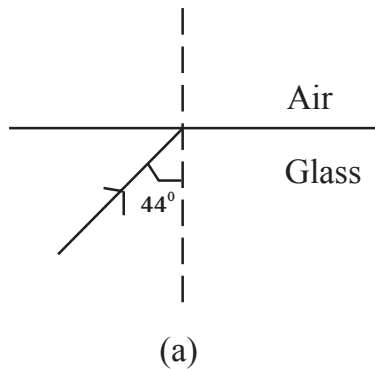

59. a) Explain Energy conversion in Hydroelectric station.  
b) Give 2 examples of Hydroelectric power stations.
60. Normally we observe beam of light through the slit of window, door etc.  
Explain the optical phenomenon behind it?

### 3 Marks Questions

61. Observe the figure.

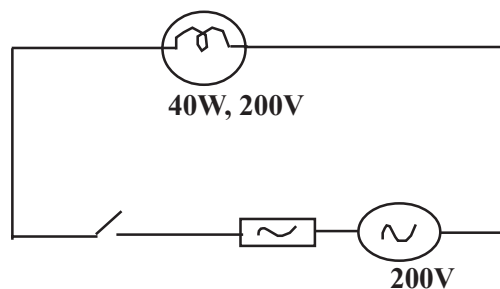

- a) Calculate the amperage of the fuse needed for the circuit. (The amperage of fuses available in market are 1A, 1.25A, 1.5A, 2.2A, 5A, 10A etc. (1)
- b) If the voltage is drops to 100V. Calculate the power of the bulb. (2)

62. Observe both the circuit.

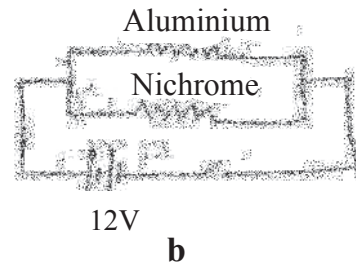
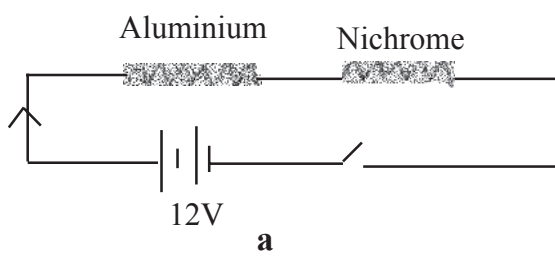

a) In figure (a), in which resistor more heat is produced ?

(Aluminium/Nichrome) (1/2)

b) In figure (b), in which resistor more heat is produced ?

(Aluminium/Nichrome) (2)

c) Give reason for both

63. a) What is the reason for exerting force on a current carrying conductor placed in a magnetic field ? (1)

b) Write down the factors affecting force on the conductor. (1)

c) Name the principle needed to find the direction of the force. (1)

64. Coils wound around a soft iron core connects two bulbs  $B_1$  and  $B_2$  of 6V. Analyse the figure and answer the questions.

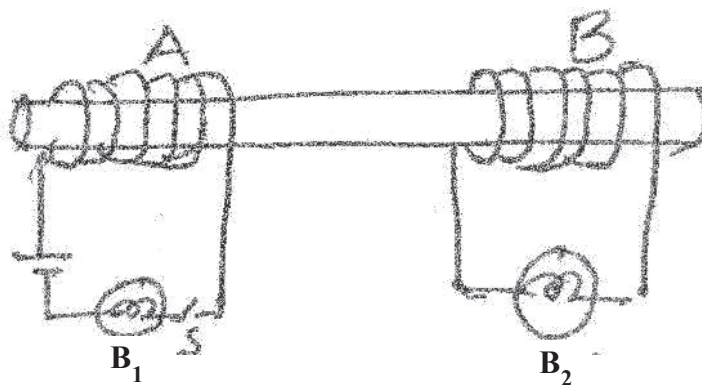

a) If 6V dc is given in the coil A and the switch is on which of bulbs  $B_1$ ,  $B_2$  will glow? Why? (1/2)

b) If AC is given in the coil A instead of DC, which of the bulb will glow -  $B_1$  or  $B_2$  ? Why ?

65. An inductor is an insulated copper wire wound in a helical shape.

a) What is the use of inductor in a circuit?

b) In circuits resistors and inductors are used for same purpose. Which is more suitable ? Why ?

66. Observe the figure.

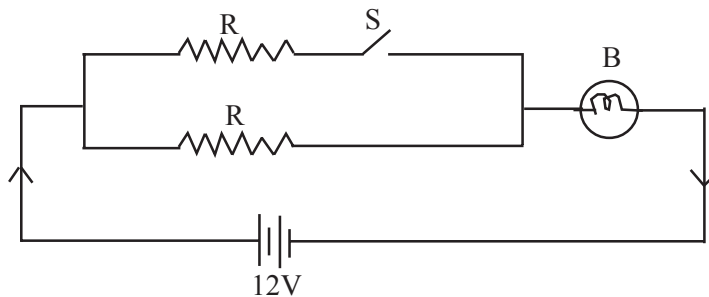

a) If the switch is ON how will the intensity of bulb change? And if it is in off condition how will the intensity vary? (1)

b) Justify your answer. (2)

67. The figure below shows a DC motor.

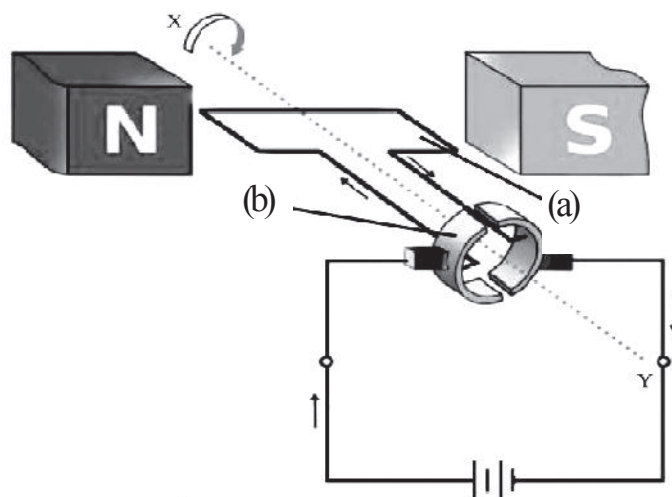

a) Name the parts which is marked as (a) and (b)?

b) What is the function of (b) marked in above figure?

c) Differentiate the working principle of dc motor and dc generator?



68. March the following

A	B
1. Fleming's right hand rule	1. DC motor
2. Slip ring	2. Direction of induced current
3. Split ring	3. Direction of motion of conductor
	4. AC generator

69. Observe the figure.

(Critical angle of glass is  $42^\circ$ )

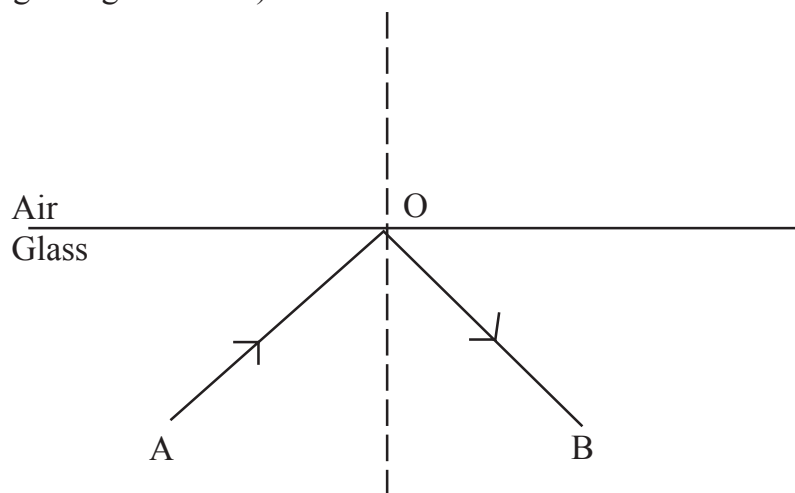

a) Here the light ray. AO is reflected as OB in the same medium. Write one circumstance for that type of reflection?

b) Name this phenomenon?

c) If the incident angle is  $42^\circ$ . What will be the refracted angle?

70. a) Find out the mirror with maximum field of view from the bracket?

(Concave mirror, Convex mirror, Plane mirror)

b) Complete the following table

Mirror	Used for
Plane mirror	.....(a).....
Concave	.....(b).....

71. a) Which are the circumstances that cause high electric current, leading to the melting of fuse wire?  
 b) When fuse wire is included in a household wiring, what are the precautions to be taken?

72. Rearrange the flow chart, which shows the working of moving coil microphone.  
 a)

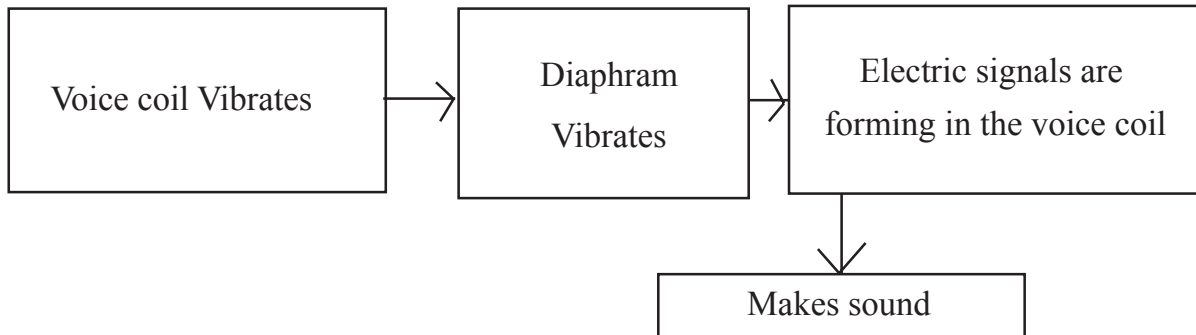

- b) Find out one difference between working of moving coil microphone and moving coil loudspeaker?

73. Match the following

A	B
a) Concave mirror	1) Virtual image with same size of object
b) Plane mirror	2) Virtual image with small size
c) Convex mirror	3) Virtual image with large size of object

- 74.

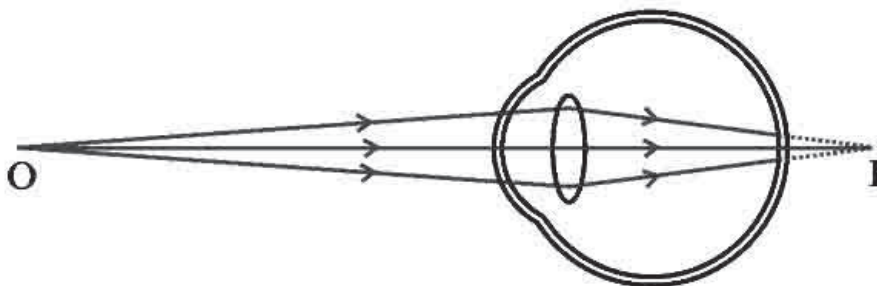

This is the picture of image formation of one's eye.

- a) What is the name of defect of eye of that person?
- b) What is the cause for this eye issue?
- c) How can we correct this defect?

- 75.
- a) What do you mean by light pollution?
  - b) Which week is observed as International dark sky week?
  - c) What is the aim of this observation?

76. Observe the figure

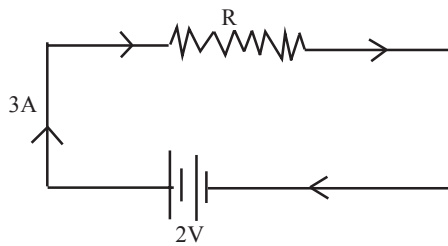

- a) Find out the quantity of charge flowing through the resistor in 1 second?
- b) Calculate the work done by the battery in one second to move this charge through the resistor?
- c) Calculate the power of the Battery?

77. Analyse the table and complete it.

A	B
<p style="text-align: center;">AC</p>	<ul style="list-style-type: none"> <li>* Change the direction continuously</li> <li>* .....(A).....</li> </ul>
<p style="text-align: center;">Battery DC</p>	<ul style="list-style-type: none"> <li>* .....(B).....</li> <li>* emf is not increasing or decreasing</li> </ul>
<p style="text-align: center;">Generator DC</p>	<ul style="list-style-type: none"> <li>* .....(C).....</li> <li>* emf is increasing and decreasing</li> </ul>

78. Observe the circuits

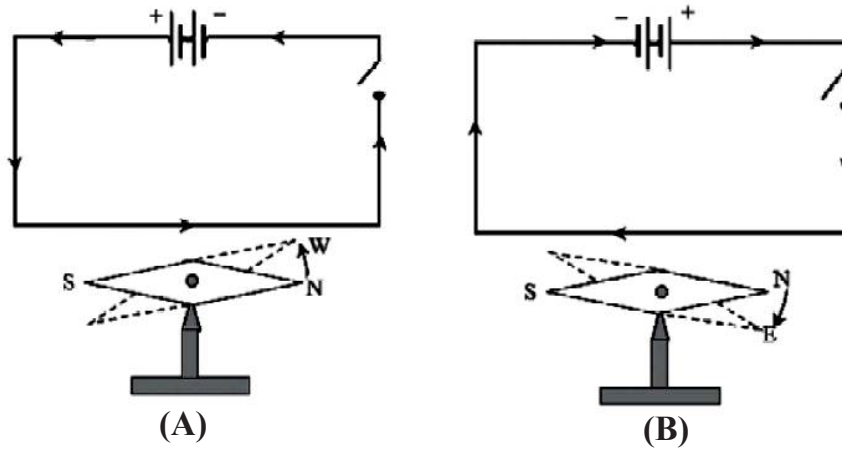

- a) What happens to the magnetic needles in the both circuit, when the switch is on?
- b) What is the difference in movement of needle?
- c) By using which law you concluded to a decision?

79. If the magnification of an image formed by a concave mirror is - 1

- a) Where will be the position of the object?
- b) Where will be the position of the image?
- c) Write the characteristics of the image?

80. We can see the path of light rays in misty mornings.

- a) Name the phenomenon?
- b) Write the definition of the phenomenon
- c) It's intensity is related to .....

81. Observe the figure and find the answer.

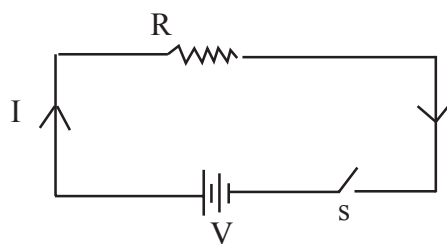

In 1 second 200J of heat energy is producing in this circuit.

a) If the resistance is  $\frac{R}{2}$ , Calculate current in this circuit?

( $\frac{I}{2}$ ,  $2I$ ,  $I$ ,  $4I$ )

b) Then how much will be the heat energy produced in this circuit?

(100J, 200J, 800J, 400J)

c) Name the law which used to find the heat energy in the circuit?

82. Observe the figure and find out the answer.

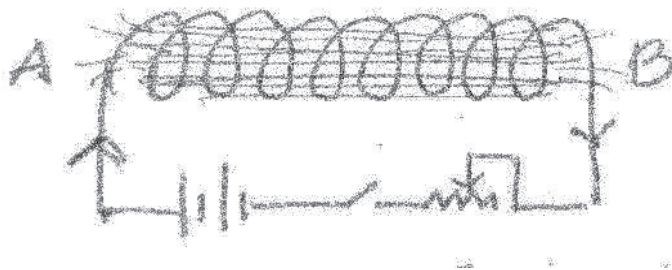

a) If the end A of a solenoid is wound anticlock wise direction. The end A will act as which pole?

b) The direction of current is opposite and bring a south pole of a magnet near to end A. Whether end A attract or repel? Give reasons.

83. Observe the figure and find the answer

A	B
1) Electromagnetic induction	a) Transformer
2) Mutual induction	b) Moving coil loud speaker
3) Self induction	c) Moving coil microphone
	d. Inductor

84. Some statements are given about the image formation of lens. Differentiate them and tabulate in to coloumns of real image and virtual image.

- a) Inverted
- b) Erect
- c) Can focus into screen

- d) Cannot focus in the screen
- e) Magnification is negative
- f) Image will be at the same side of the object.

85. a) Write down 2 examples for Biomass?  
 b) What are 2 important consequences of making biomass as fuel?  
 c) How can we manage biomass in to eco-friendly energy form?

### 4 Marks Questions

86. Electric heating appliances have a main part in which electrical energy changes into heat energy.

- a) Name the part (1)
- b) Which material is used to that part (1)
- c) What are the peculiarities of this part (2)

87. The following figure represents a bar magnet and electro magnet.



Bar Magnet



- a) Find out the polarity at the End of A? (1)
- b) Name the law which help to find the direction of magetic field ? (1)
- c) Write any 2 difference between bar magnet and electromagnet (2)

88. Observe the figure.

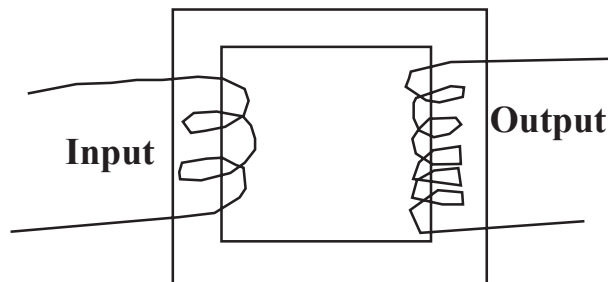

- a) Name the device given (1)
- b) Write the working Principle. (1)
- c) This transformer has 5 turn in primary and 25 turns in secondary. Find out the output voltage when the primary coil has 10V ?

89. Complete the given table (4)

Angle( $\theta$ )	No. of imges (n)
$45^{\circ}$	...(a)...
...(b)...	5
$90^{\circ}$	...(c)...
$120^{\circ}$	...(d)...

90. Absolute refractive index of two mediam are given below. Answer the following questions.

Mediam A = 1.5 ; B = 2.25 (Velocity of light in air is  $3 \times 10^8 \text{m/s}$ )

- a) Which mediam has greater optical density? (1)
- b) Which Mediam has greater speed of light? (1)
- c) Calculate the speed of light in mediam A? (2)

91. Observe and analyse the figure?

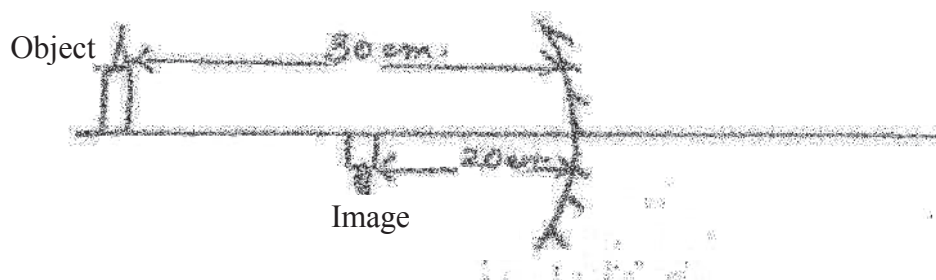

- a) Identify the mirror? (1)
- b) Peculiarities of the image than object? (1)
- c) Find out the focal length of the mirror? (2)

92. An object OB is placed in front of the convex lens.

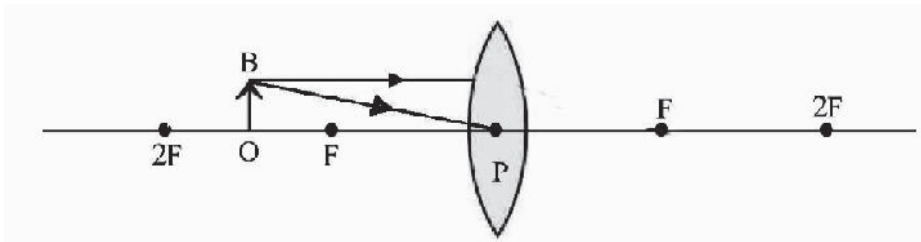

- a) By the help of incident rays draw the image formation? (2)
- b) What are the properties of the image? (2)

93. a) Identify the phenomenon of light from the figure? (1)

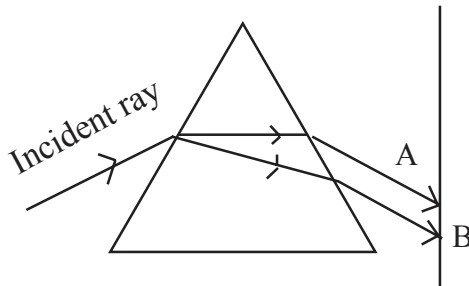

- b) If the incident ray is white light then A = ..... colour and B = ..... colour. (2)
- c) If the incident ray is green light, then the colour obtained on the screen is ..... (1)

94. Electric bulbs are examples of lighting effect of electricity.

- a) Name the material used for the preparing the filament of electric bulb? (1)
- b) What are the peculiarities of this material? (1)
- c) The efficiency of incandascnt lamp is less. Why? (2)

95. A transformer which has no powerloss has 200 turn in primary and 2000 turn in secondary. Now the primary has 0.5A intensity of electric current and 240V then find out the secondary voltage and secondary current?



96. An heating coil of 550 ohm resistance working on 220V.

- a) Find out the electric current in the circuit?
- b) Find out the heat energy in 5 minutes?
- c) Write the equation to calculate electric power?

97. Most of the countries facing the problem Energy Crisis.

- a) Define energy crisis?
- b) Solutions for minimising energy crisis?

98. Observe the magnetic field of the solenoid in the figure.

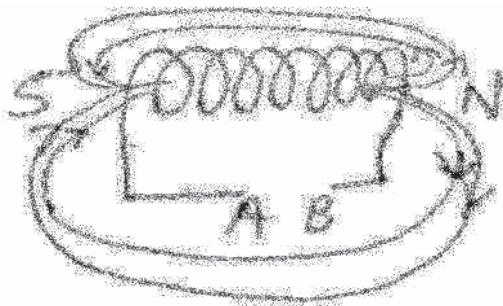

- a) Draw the complete figure and mark the poles of battery at A and B?
- b) What are the factors effecting the magnetic field of a solenoid?

99. Observe the figure.

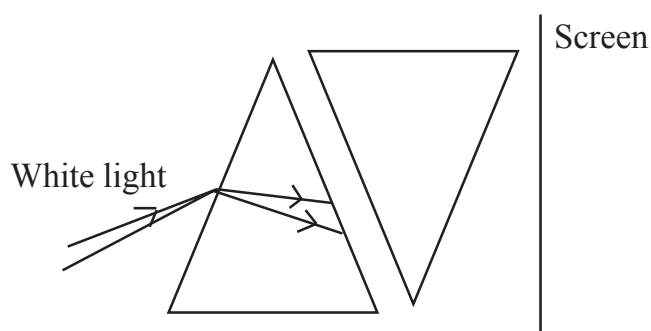

- a) Complete the figure? (2)
- b) Which colour is obtained on the screen? (1)
- c) Identify the phenomenon of light happening in the first prism? (1)

100. Based on household electrification. Find out the answer?

- a) Electric switches and fuse are arranged in which electric line? (1)
- b) The earth wire is connected which part of the Iron box? What are the difference of this pin than others? (2)
- c) Which method is adopt to arrange the switches and fuse in the electric line? (1)

101. An electrical appliance marked 230V, 960W has connected to the output of a transformer.

- a) The primary voltage is 115V. Then identify the type of transformer
- b) Find out the electric current flowing both in primary and secondary?

102. You are familiar with cooking gas.

- a) Identify the fuel which is using as cooking gas?
- b) This gas is a colourless odourless gas. But it produces an odour when there is leakage of gas. Give reason?
- c) It is marked D22 on a gas cylinder. What do you understand from this
- d) What are the precautions to be taken to avoid accidents due to leakage of gas.

103. a) Identify the mirror which show always small and erect image?

- b) Name the situation using their type of mirror?
- c) Which part of this mirror helps to form such images?

104. Light emitting diodes are LED bulbs.

- a) What are the main parts of LED bulbs?
- b) What are the importance of LED bulbs than other bulbs?

105. a) Observe the figure and find out the values according to New Cartesian sign convention.?

(u, v, f, h<sub>o</sub>, h<sub>i</sub>)

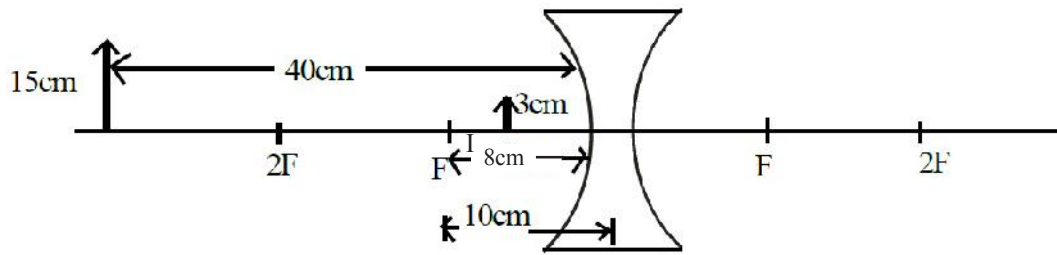

b) Calculate the magnification of this image?

106. Observe the figure.

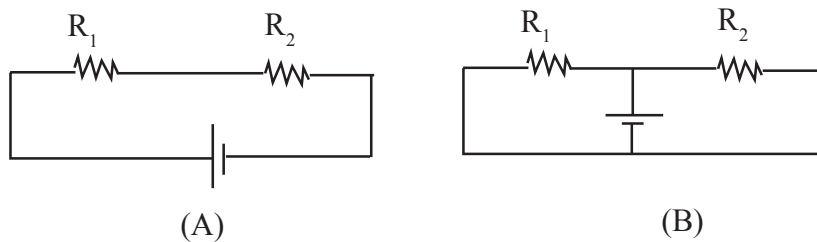

- Draw the circuits A, B and mark the direction of current?
- Write the equations to find out the effective resistance in the circuits A, B?

107. The two ends of a solenoid is connected to the galvanometer and a bar magnet is moving inwards and outwards of the solenoid continuously.

- What happens to the needle of the galvanometer and find out phenomenon behind it?
- To increase the intensity of electric current in the circuit what are the factors to be considered?

108. A lens, which has always produce a virtual image has a focal length 25cm.

- Identify the type of lens?
- What are the other peculiarities of the image?
- Calculate the power of this lens?

109. Newton's colour disc is an example pf Persistence of vision.

- What are the colour's arranged on a Newton's colour dic?
- Which colour has seen when it is rotating very fastly?
- Explain the phenomenon Persistence of Vision?

110. a) Complete the table

Mirror	Situation used
Plane mirror	.....(a).....
Concave	.....(b).....
Convex mirror	.....(c).....

b) From these mirrors whichc has more aperture...?.

111. An object is placed at a distance of 15 cm. in front of a mirror. According to new cartesian sign convention focal length is - 6 cm.

- a) What type of mirror is this (1)
- b) Calculate the distance between the mirror and image. (2)
- c) If the magnification of the image of an object of length 3 cm by a mirror is -2, find the height of the image (1)

112. a) What are the similiarities and differences between a moving coil microphone and a moving coil loudspeaker? (2)

b) Which device is used for strengthening the weak signal obtained from Microphone? (1)

c) Name a device which works on same principle of moving coil microphone. (1)

113. Two resistance of  $3\Omega$ ,  $6\Omega$ , 6V battery and switch are given,

- a) Depict a figure of series connection using these component? (1)
- b) Calculate the effective resistance of series connection? (1)
- c) Calculate the current in this circuit? (1)
- d) Calculate the effective resistance, if resistors are connected in parallel? (1)

114. Some light conducting media are given in the bracket.

(Air, Diamond, Water, Glass)

- a) Which of these has greater optical density? (1)
- b) Arrange the media in the decreasing order of their speed of light? (1)
- c) What is the relation between optical density and speed of light? (1)
- d) When light passes from water to glass, what happens to the path of light? (1)

115. The figure of a generator is given.

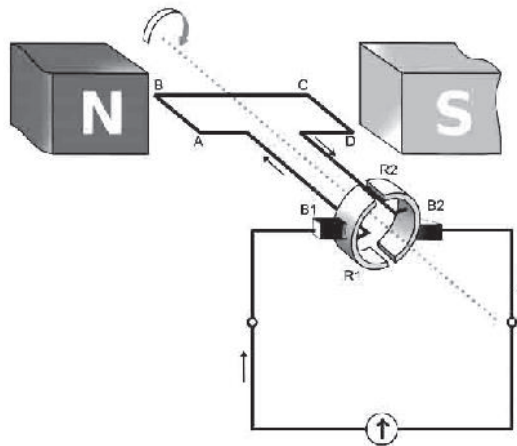

- a) Identify the generator? (1)
- b) What is the structural difference between AC generator and DC generator?(1)
- c) What is the energy change that takes place in a motor and in a generator? (1)
- d) Eventhough the induced emf is AC, the current produced by a DC generator is DC. How? (1)

116. Choose the appropriate words from bracket related to following statements.

(Concave, Convex, Real, Virtual, Principal focus, Pole)

- a) Rear view mirror in vehicles is ..... (1)
- b) According to New cartesian sign convention, distances are measured from the ..... (1)

- c) When the magnification of a mirror is positive, the image is ..... (1)
- d) ..... mirror is used as solar concentrators. (1)

117. The following figure shows that the image formation in the eye of a person.

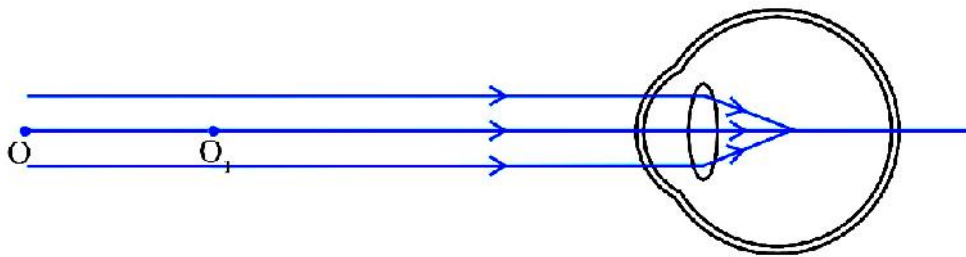

- a) Identify the eye defect of the person? (½)
- b) What are the reasons behind this defect? (1)
- c) How can it be rectified? (½)
- d) Draw its ray diagram? (2)

118. When electricity is transmitted to distant places there is loss of energy in the conductors in the form of heat.

- a) What are the methods to reduce heat generated? (1)
- b) Which type of transformer is there in power station? (½)
- c) Which type of transformer is a distribution transformer? (½)
- d) If a person standing on the earth touches a phase line, will he get an electric shock? Why? (1)
- e) What is the potential difference between 2 phase line? (1)

119. a) Complete the following ray diagram (1)

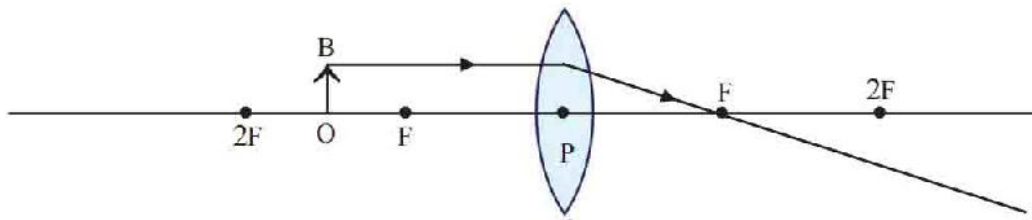

- b) Write the position of the image formed? (1)
- c) Write down the nature of the image? (1)
- d) If concave lens is placed instead of convex lens in the above figure, what will be position and nature of the image formed? (1)
120. A copper wire and a Nichrome wire of same length and diameter are connected in series in a circuit. When the current flow through the circuit,
- a) Which one will be heated more? Why? (1)
- b) Which law will help to calculate the heat generated in the conductor? (1)
- c) A current of 1A flow through an electrical device of resistance  $100\Omega$ . If this device works for 5 minutes. Calculate the heat generated? (2)

**EQUIP - DIET KASARAGOD**  
**SSLC QUESTION POOL**  
**PHYSICS - ENGLISH MEDIUM**

---

**1 Mark Question - Answers**

1. Peat. Remaining substances obtained when coal is distilled in the absence of air.
2. Refraction
3. 11000V or 11Kv
4. Convex Mirror
5. Concave lens
6. Motor principle
7. Loss of energy in the form of heat
8. Butane
9.  $\frac{3 \times 10^8}{2 \times 10^8} = 1.5$
10. Heating effect
11. Electric energy to mechanical energy
12. 50Hz
13. 24cm
14.  $90^\circ$
15. Fossil fuel, Fossil fuel is brown energy. Remaining are Green energy
16. White persistence of vision
17. -1
18. Metal part
19.  $P=IR^2$
20. Voice coil
21. Phase line
22. More deviate  $\longrightarrow$  Violet  
Less deviate  $\longrightarrow$  Red



23. Ethyl mercaptan
24. Near sightedness
25. Inductor
26. The amount of heat liberated by the complete combustion of 1kg of fuel is its Calorific value.
27. Near point : 25 cm  
Far point : Infinity
28.  $\frac{1}{4}$
29. (c) Low melting point
30. Electromagnetic induction
31. Between F and 2F
32. Red colour has more wave length. Hence it scatters less.
33. Liquefied Petroleum Gas
34. 2
35. Fuels obtained from plants and animals
36. In parallel manner
37. Resistance : ohm
38. Short circuit  
Over loading
39. Coal
40.  $P = \frac{100}{f(cm)} = \frac{100}{50} = +2D$
41. Between 'F' and 'P'
42. 400V
43. Satellite
44.  $h_0 = 4\text{cm}$ ,  $h_i = ?$   
 $m = -2$   
 $m = \frac{h_i}{h_o} = -2 = \frac{h_i}{4}$

$$h_i = -2 \times 4$$
$$= -8 \text{ cm}$$

45. Thumb  $\longrightarrow$  force  
Middle finger  $\longrightarrow$  current

### **2 Marks Questions - Answers**

46. a) Reflective =  $\frac{R}{n} = \frac{3\Omega}{10} = 0.3\Omega$
47. When solar energy /Light Energy falls on N side of PN junction diode, a small electric current is obtained due to the flow of electrons to P region from N region. This phenomenon is called photovoltaic effect.
48. Earth pin is thick and long. As it is long it first comes in contact with the earth. Similarly it loses the contact with the earth only at the end. As it is thick it offers less resistance. Hence it carries more current.
49. 1. Number of turns in the solenoid  
2. Intensity of current  
3. Area of cross section of the soft Iron core.
50. Persistence of vision  
When an object is viewed by a person, its image remains in the retina of the eye for a time interval of  $(0.065 \text{ s}) \frac{1}{16} \text{ s}$  after seeing it.
51. On complete combustion of 1kg of the fuel produced a heat energy of 45000KJ.  
Availability, easy to transport, easy to handle.
52. (i) Intensity of light connected in bulb (fig.b) is less when it is switched 'ON'  
(ii) Due to back emf
53. Atmospheric refraction  
Bending of ray of light when it is travelling from one transparent medium to another.

54. Into the paper.

Flemings Left Hand Rule.

If we stretch forefinger, middle finger and thumb of our left hand in mutually in direction then fore finger indicate diretion of magnetic field, middle finger indicate direction of current and thumb indicate direction of force.

55. (ii) and (iii)

56. More life span

Less consumption of electricity

More light

57. We can observe a bend in pencil at the surface of separation of air and water. It is due to refraction. Bending of ray of light when it is travelling from one medium to another.

58.

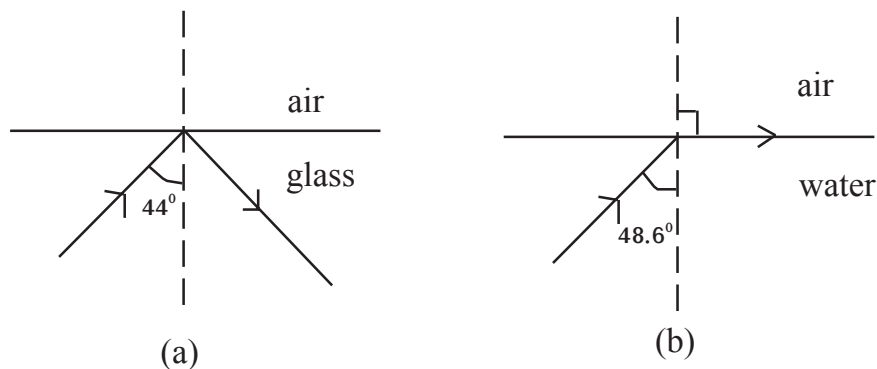

59. a) Potential Energy  $\longrightarrow$  Kinetic Energy  $\longrightarrow$   
Mechanical Energy  $\longrightarrow$  Electrified Energy

b) Pallivasal Kuttiyadi

Moolamattam

60. Tyndal Effect

When rays of light pass through a colloid or suspension, the tiny particle get illuminated due to scattering. Because of this path of light is made visible. This phenomenon is called Tyndal Effect.

### 3 Marks Questions - Answers

61. a) 
$$A = \frac{W}{V}$$
$$= \frac{40}{200} = 0.2A$$
$$= 1A$$

b)

$$R = \frac{V^2}{P} = \frac{200 \times 200}{40} = 1000\Omega$$

$V = 100V, R = 1000\Omega$

$$P = \frac{V^2}{R} = \frac{100 \times 100}{1000} = 10W$$

62. a) Nichrome

b) Aluminium

c) Fig (a), series connection - same current flows  $H=I^2Rt$  which resistor has greater R, it produces more heat.

Fig (b) - Parallel connection. Aluminium less resistance. So more current flow through it and heat generated is more.

63. a) Surrounding the current carrying conductor there will be a magnetic field. Both magnetic fields coming in action and hence there is a force.

b) Current, strength of magnetic field.

c) Fleming's left hand rule.

64. a) B1. Because Dc is applying. There will be no changing magnetic field. No mutual induction.

b) B1 and B2.. These is a varying magnetic field and mutual induction takes place.

- 
65. a) To control ac in a circuit with out power loss.  
b) Inductor  
Resistor - There will be energy loss in the form of heat.  
Inductor - There will be no power loss.
- 66 a) If the switch is ON, The bulb 'B' glows more. If the switch is OFF, The bulb 'B' glows less.  
b) When switch is ON, effective R will be less and current will be more.  
Hence more glow.  
When such is OFF, first resistance is not in circuit and total R will be a greater value. Hence less cureernt and less glow.
67. a) a- Armature  
b - Split ring  
b) To change the direction of current  
c) DC Motor - Motor Principle  
DC Generator - Electro Magnetic Induction.
68. a - 2  
b - 4  
c - 1
69. a) Light should travel from denser medium to rarer medium.  
b) Total Internal reflection  
c)  $90^\circ$
70. a) Convex mirror  
b) a) To see face  
b) Shaving mirror
71. a) Short circuit  
Overloading  
b) 1) The ends of the fuse wire must be connected firmly at appropriate points.  
2) The fuse wire should not project out of the carrier base.

72 a)

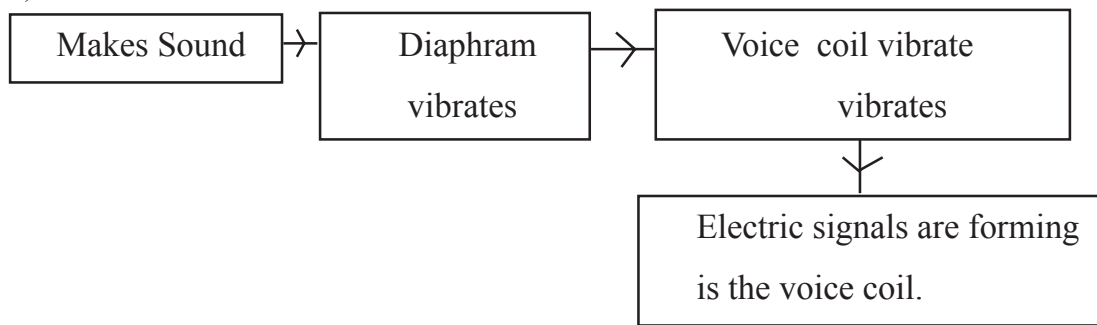

b) Microphone - Mechanical Energy to Electrical Energy

Loud Speaker - Electrical Energy to Mechanical Energy

73. Match the following

a - 3

b - 1

c - 2

74. a) Long sightedness (Hypermetropia)

b) 1) Smaller size of eye ball

2) Low power of eyes

c) By using convex lens of suitable power.

75. a) The use of light in excess in a non-judicious manner is known as Light Pollution.

b) The week of the new moon in April

c) To aware the concecutions of light pollution.

76. a)  $Q = Ixt$   
 $3 \times 1 = 3C$

b)  $W = V \times Q$   
 $= 2 \times 3 = 6J$

c)  $P = V \times I$   
 $= 2 \times 3 = 6W$

77. a) emf is increasing and decreasing

b) Direction is not changing

c) Direction is not changing

78. a) Both - Vibrates  
 b) A - Anticlock wise  
     B - Clockwise  
 c) Right hand thumb rule
79. a) at C (2F)  
 b) at C (2F)  
 c) Real, Inverted
80. a) Tyndal effect  
 b) When rays of light pass through a colloidal fluid the tiny particles get illuminated due to scattering. Due to this path of light is made visible.  
 c) Size of particles
81. a)  $2I$   
 b)  $H = I^2Rt$   
 $= (2I)^2 \times \frac{R}{2} \times t$   
 $= 2I^2Rt$   
 $= 2 \times 200J = \mathbf{400J}$   
 c) Joule's law
82. a) North pole  
 b) Repel. Because now the end A is acting as south pole
83. Match the following

A	B
1	c
2	a
3	d

84.

Real Image	Virtual image
a	b
c	d
e	f

85. a) Fire wood, cow dung cake

- b) 1. Air pollution  
2. Health pollution

c) Biogas plant

#### **4 Marks Questions - Answers**

86.

- a) Heating coil  
b) Nichrome  
c) High melting point, high resistivity, becomes red hot for a long time.  
(Any 2)

87. a) North pole

b) Right hand thumb rule - James clerk maxwell

c) Bar magnet - magnetic power cannot change permanent

Electro magnet - magnetic power changes according to the intensity of electric power temporary. When the electricity is out off magnetic power loss.

88. a) Step up transformer

b) Mutual induction

c)  $\frac{V_1}{N_1} = \frac{V_2}{N_2}$        $\frac{10}{5} = \frac{V_2}{25}$        $V_2 = 50V$



89. No. of Images  $n = \frac{360}{\theta} - 1$

- a) 7
- b)  $60^\circ$
- c) 3
- d) 2

90. a) Median B

b) Median A

c)  $n = \frac{c}{v}$      $V = \frac{c}{n}$   
 $V = \frac{3 \times 10^8}{1.5} = 2 \times 10^8 \text{ m/s}$

91. a) Concave mirror

b) Real, inverted and smaller than object.

c)  $f = \frac{uv}{u+v}$ ;  $f = \frac{(-30) \times (-15)}{-30 + -15}$ ;  $f = \frac{450}{-45} = -10 \text{ cm}$

92. a)

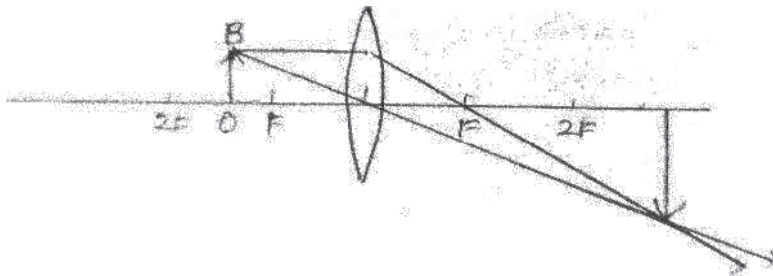

b) Inverted, Real & bigger than object

93. a) Dispersion of light

b) A = Red, B = Violet

c) Green (not a composite light)

94. a) Tungston

b) High resistivity, high melting point

c) Most of the electric energy is loss as heat energy.

95. a)  $\frac{V_s}{V_p} = \frac{N_s}{N_p}$ ;

$$V_s = \frac{V_p \times N_s}{N_p}; V_s = \frac{240 \times 200}{2000}; V_s = 24V$$

$$V_s \times I_s = V_p \times I_p; I_s = \frac{V_p \times I_p}{V_s}; I_s = \frac{240 \times 0.5}{24}; I_s = 5A$$

96. a)  $I = \frac{V}{R}; I = \frac{220}{5} I = 4A$

b)  $H = I^2 R t$  ( $H = VI t; H = \frac{V^2}{R} t$ ) (½ mark)

$$H = 4 \times 4 \times 55 \times 5 \times 60; H = 220 \times 4 \times 300 \text{ (1 mark)}$$

$$H = 26400J \text{ (½ mark)}$$

c)  $P = VI$  (OR)  $P = I^2 R$  (OR)  $P = \frac{V^2}{R}$  (1 mark)

97. a) Increasing demand and decreasing availability of resources energy crisis.

- b) 1) Judicious utilization of energy  
 2) Maximum utilization of solar energy  
 3) Minimising the wastage of water?

98. a)

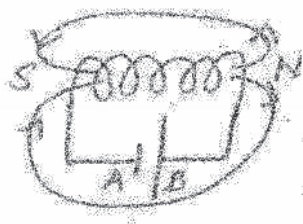

A = Negative

B = Positive

b) (i) No. of turns in the Solenoid (ii) Intensity of current

99. a)

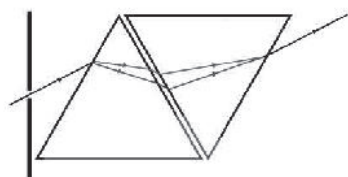

- b) White
- c) Dispersion of light. White light is a composite light.
100. a) Phase
- b) The earth wire is connected to the metallic part of Iron box.  
The differences are thicker and longer than other pins.
- c) Parallel
101. a) Step up transformer
- b) Intensity of electric current is  
Secondary :  $P = VI$  ;  $I = \frac{P}{V}$  ;  $I = \frac{960}{230}$  ;  $I = 4.17A$   
Power is same in both circuits in a transformer.  
Primary :  $P = VI$  ;  $I = \frac{P}{V}$  ;  $I = \frac{960}{115}$  ;  $I = 8.34A$
102. a) LPG / Butane /  $C^4H^{10}$
- b) Ethyl Mercaptan is added for odour
- c) The expiry time is December 2022.
- d) Check the rubber tube frequently, Observe the knob only after opening the Regulator.
103. a) Convex mirror
- b) Rearview mirror
- c) It has a large aperture
104. a) Base unit, Power supply unit, Heat sink, Printed circuit board, Diffuser cup., base plate (Any 2)
- b) No heat loss, No environmental pollution, Easy to handle, Less power consumption (Any 2)
105. a)  $u = -40cm$   
 $v = -8$

$$f = -10\text{cm}$$

$$h_i = 3\text{cm}$$

$$h_o = 15\text{cm}$$

b) Magnification (m)  $\frac{h_i}{h_o}$  OR  $\frac{v}{u}$

$$m = \frac{3\text{cm}}{15\text{cm}} \text{ or } \frac{-8\text{cm}}{-40\text{cm}} = \frac{1}{5}$$

106 a)

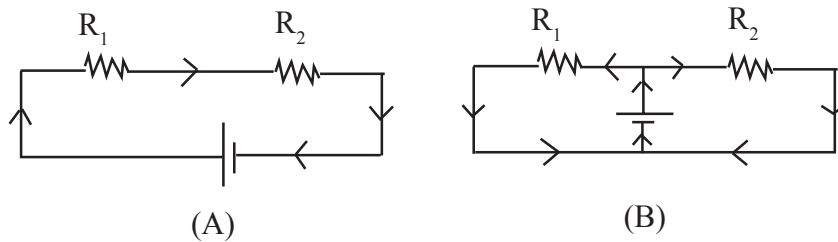

b) Circuit A ;  $R = R_1 + R_2$

Circuit B ;  $R = \frac{R_1 R_2}{R_1 + R_2}$

OR  $\frac{1}{R} = \frac{1}{R_1} + \frac{1}{R_2}$

107. a) Galvanometer needle deflects

Reason : Electromagnetic Induction

b) Factors:

- 1) Number of turns in the solenoid
- 2) The speed of bar magnet
- 3) The magnetic power of bar magnet

When these are increased intensities of electricity increases in the circuit.

108. a) Concave lens

b) Small, erect

c) Power of lens  $P = \frac{1}{\text{focal length of lens in meter}}$

$$P = \frac{1}{\frac{-25}{100}} : P = \frac{100}{25} : P = -4D$$

109. a) VIBGYOR  
 b) White  
 c) The image remains in the retina  $\frac{1}{16}$  seconds only OR 0.0625 second.

110. a)

Mirror	Used situation
Plane mirror	a) Looking face
Concave	b) ENT head mirror/search light Dentist mirror/shaving mirror
Convex mirror	c) Rear view mirror

b) Convex mirror

- 111 a) Concave  
 b)  $u = -15\text{cm}$   
 $f = -6\text{cm}$

$$\frac{1}{f} = \frac{1}{u} + \frac{1}{v}$$

$$\frac{1}{v} = \frac{1}{f} - \frac{1}{u}$$

$$V = \frac{uf}{u-f} = \frac{(-15) \times (-6)}{(-15) - (-6)}$$

$$= \frac{+90}{-9} = -10\text{cm}$$

c)  $h_o = 3\text{cm}$

$$m = -2$$

$$m = \frac{h_i}{h_o}$$

$$-2 = \frac{h_i}{3}$$

$$h_i = -2 \times 3 = -6 \text{ cm}$$

112. a) Similarities - Permanent Magnet, Voice coil, Diaphragm.

Difference	Microphone	Loud Speaker
Working Principle	Electromagnetic Induction	Motor Principle
Energy change	Mechanical Energy to Electrical Energy	Electrical Energy to Mechanical Energy

b) Amplifier

c) Generator (ac/dc)

113. a)

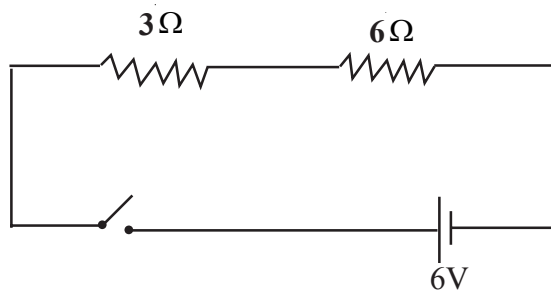

b) Effective resistance  $R = R_1 + R_2$

$$= 3 + 6 = 9 \Omega$$

c) Current  $I = \frac{V}{R}$  (Ohm's law)

$$= \frac{6}{9} A \quad \text{Or} \quad \frac{2}{3} A$$

$$d) R = \frac{R_1 R_2}{R_1 + R_2} = \frac{3 \times 6}{3 + 6}$$

$$= \frac{18}{9} = \underline{\underline{2\Omega}}$$

114. a) Diamond  
 b) Air, Water, Glass, Diamond  
 c) As optical density increases, speed of light decreases  
 d) Deviate towards the normal
115. a) DC Generator  
 b) Split Rings in DC generator  
 Slip Rings in AC generator  
 c) Generator - Mechanical Energy to Electrical Energy  
 Motor - Electrical Energy to Mechanical Energy  
 d) By using split ring commutator
116. a) Convex  
 b) Pole  
 c) Virtual  
 d) Concave
117. a) Myopea (Near Sightedness)  
 b) Size of the eye ball is larger  
 Focal length of lens is low (power is high)  
 c) By using a concave lens of suitable power.  
 d)

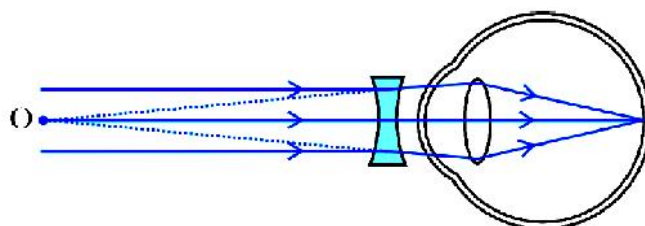

118. a) Reduce current and resistance  
 b) Step up transformer  
 c) Step down transformer  
 d) Get electrical shock. Because there is a potential difference between earth and a phase line is 230V.  
 e) 400V

119. a)

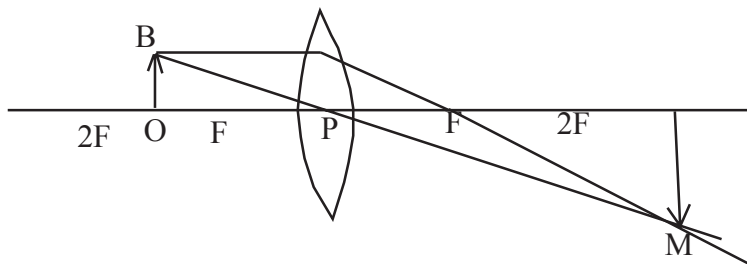

- b) Beyond 2F  
 c) Real, inverted, enlarged (Any 2)  
 d) Position - Infront of the lens, between P and F of the same side.  
 Nature - Virtual, Erect, Diminished

120. a) Nichrome wire, Due to high resistance

- b) Joule's law  
 c)  $R = 100\Omega$ ,

$$I = 1A$$

$$t = 5 \text{ minutes} = 5 \times 60 \text{ seconds}$$

$$H = I^2 R t$$

$$I^2 \times 100 \times 5 \times 60$$

$$= 30000J$$

