

Strictly based on the latest ICSE Curriculum

 **OSWAAL BOOKS**
LEARNING MADE SIMPLE

For
2019
Exam



ICSE



SOLVED PAPER 2018



CLASS 10

PHYSICS



 **OSWAAL BOOKS**

1/11, Sahitya Kunj, M.G. Road,

Agra - 282002, UP (India)

Ph.: 0562 2857671, 2527781

email: contact@oswaalbooks.com

website: www.oswaalbooks.com

0504

Disclaimer :

Oswaal Books has exercised due care and caution in collecting the data before publishing this book. In spite of this if any omission, inaccuracy or printing error occurs with regards to the data contained in this book, Oswaal books will not be held responsible or liable. Oswaal Books will be grateful if you could point out any such error or your suggestions which will be of great help for other readers.



LATEST SYLLABUS

PHYSICS

CLASS 10

There will be one paper of two hours duration carrying 80 marks and Internal Assessment of practical work carrying 20 marks. The paper will be divided into **two** sections, Section I (40 marks) and Section II (40 marks).

Section I (compulsory) will contain short answer questions on the entire syllabus.

Section II will contain six questions. Candidates will be required to answer any four of these six questions.

Note: Unless otherwise specified, only S. I. Units are to be used while teaching and learning, as well as for answering questions.

1. Force, Work, Power and Energy

- (i) Turning forces concept; moment of a force; forces in equilibrium; centre of gravity; [discussions using simple examples and simple numerical problems].

Elementary introduction of translational and rotational motions; moment (turning effect) of a force, also called torque and its cgs and SI units; common examples—door, steering wheel, bicycle pedal, etc.; clockwise and anti-clockwise moments; conditions for a body to be in equilibrium (translational and rotational); principle of moment and its verification using a metre rule suspended by two spring balances with slotted weights hanging from it; simple numerical problems; Centre of gravity (qualitative only) with examples of some regular bodies and irregular lamina.

- (ii) Uniform circular motion.

As an example of constant speed, though acceleration (force) is present. Differences between centrifugal and centripetal force.

- (iii) Work, energy, power and their relation with force.

Definition of work. $W = FS \cos\theta$; special cases of $\theta = 0^\circ, 90^\circ$. $W = mgh$. Definition of energy, energy as work done. Various units of work and energy and their relation with SI units. [erg, calorie, kW h and eV]. Definition of Power, $P = W/t$; SI and cgs units; other units, kilowatt (kW), megawatt (MW) and gigawatt (GW); and horse power (1hp=746W) [Simple numerical problems on work, power and energy].

- (iv) Different types of energy (e.g. chemical energy, Mechanical energy, heat energy, electrical energy, nuclear energy, sound energy, light energy).

Mechanical energy: potential energy $U = mgh$ (derivation included) gravitational PE, examples; kinetic energy $K = \frac{1}{2}mv^2$ (derivation included); forms of kinetic energy: translational, rotational and vibrational - only simple examples. [Numerical problems on K and U only in case of translational motion]; qualitative discussions of electrical, chemical, heat, nuclear, light and sound energy, conversion from one form to another; common examples.

- (v) Machines as force multipliers; load, effort, mechanical advantage, velocity ratio and efficiency; simple treatment of levers, pulley systems showing the utility of each type of machine.

Functions and uses of simple machines :

Terms—effort E , load L , mechanical advantage $MA = L/E$, velocity ratio $VR = V_E/V_L = d_E/d_L$, input (W_i), output (W_o), efficiency (η), relation between η and MA, VR (derivation included); for all practical machines $\eta < 1$; $MA < VR$.

Lever : principle. First, second and third class of levers; examples: MA and VR in each case. Examples of each of these classes of levers as also found in the human body.

Pulley system : single fixed, single movable, block and tackle; MA, VR and η in each case.

- (vi) Principle of Conservation of energy.

Statement of the principle of conservation of energy; theoretical verification that $U + K = \text{constant}$ for a freely falling body. Application of this law to simple pendulum (qualitative only); [simple numerical problems].

2. Light

- (i) Refraction of light through a glass block and a triangular prism - qualitative treatment of simple applications such as real and apparent depth of objects in water and apparent bending of sticks in water. Applications of refraction of light.

Partial reflection and refraction due to change in medium. Laws of refraction; the effect on speed (V), wavelength (λ) and frequency (f) due to refraction of light; conditions for a light ray to pass undeviated. Values of speed of light (c) in vacuum, air, water and glass; refractive index $\mu = c/V$, $V = c/\mu$. Values of μ for common substances such as water, glass and diamond; experimental verification; refraction through glass block; lateral displacement; multiple images in thick glass plate/mirror; refraction through a glass prism simple applications: real and apparent depth of objects in water; apparent bending of a stick under water. (Simple numerical problems and approximate ray diagrams required).



...contd.

- (ii) Total internal reflection: Critical angle; examples in triangular glass prisms; comparison with reflection from a plane mirror (qualitative only). Applications of total internal reflection.

Transmission of light from a denser medium (glass/water) to a rarer medium (air) at different angles of incidence; critical angle (C) $\mu = 1/\sin C$. Essential conditions for total internal reflection. Total internal reflection in a triangular glass prism; ray diagram, different cases - angles of prism ($60^\circ, 60^\circ, 60^\circ$), ($60^\circ, 30^\circ, 90^\circ$), ($45^\circ, 45^\circ, 90^\circ$); use of right angle prism to obtain $\delta = 90^\circ$ and 180° (ray diagram); comparison of total internal reflection from a prism and reflection from a plane mirror.

- (iii) Lenses (converging and diverging) including characteristics of the images formed (using ray diagrams only); magnifying glass; location of images using ray diagrams and thereby determining magnification.

- (iv) Types of lenses (converging and diverging), convex and concave, action of a lens as a set of prisms; technical terms; centre of curvature, radii of curvature, principal axis, foci, focal plane and focal length; detailed study of refraction of light in spherical lenses through ray diagrams; formation of images - principal rays or construction rays; location of images from ray diagram for various positions of a small linear object on the principal axis; characteristics of images. Sign convention and direct numerical problems using the lens formula are included. (derivation of formula not required)

Scale drawing or graphical representation of ray diagrams not required.

Power of a lens (concave and convex) – [simple direct numerical problems]; magnifying glass or simple microscope: location of image and magnification from ray diagram only [formula and numerical problems not included]. Applications of lenses.

- (v) Using a triangular prism to produce a visible spectrum from white light; Electromagnetic spectrum. Scattering of light.

Deviation produced by a triangular prism; dependence on colour (wavelength) of light; dispersion and spectrum; electromagnetic spectrum: broad classification (names only arranged in order of increasing wavelength); properties common to all electromagnetic radiations; properties and uses of infrared and ultraviolet radiation. Simple application of scattering of light e.g. blue colour of the sky.

3. Sound

- (i) Reflection of Sound Waves; echoes: their use; simple numerical problems on echoes.

Production of echoes, condition for formation of echoes; simple numerical problems; use of echoes by bats, dolphins, fishermen, medical field. SONAR.

- (ii) Natural vibrations, Damped vibrations, Forced vibrations and Resonance - a special case of forced vibrations. Meaning and simple applications of natural, damped, forced vibrations and resonance.

- (iii) Loudness, pitch and quality of sound:

Characteristics of sound: loudness and intensity; subjective and objective nature of these properties; sound level in db (as unit only); noise pollution; interdependence of: pitch and frequency; quality and waveforms (with examples).

4. Electricity and Magnetism

- (i) Ohm's Law; concepts of emf, potential difference, resistance; resistances in series and parallel, internal resistance.

Concepts of pd (V), current (I), resistance (R) and charge (Q). Ohm's law : statement, $V=IR$; SI units; experimental verification; graph of V vs I and resistance from slope; ohmic and non-ohmic resistors, factors affecting resistance (including specific resistance) and internal resistance; super conductors, electromotive force (emf); combination of resistances in series and parallel and derivation of expressions for equivalent resistance. Simple numerical problems using the above relations. [Simple network of resistors].

- (ii) Electrical power and energy.

Electrical energy; examples of heater, motor, lamp, loudspeaker, etc. Electrical power; measurement of electrical energy, $W = QV = VIt$ from the definition of pd. Combining with ohm's law $W = VI t = I^2 R t = (V^2/R)t$ and electrical power $P = (W/t) = VI = I^2 R = V^2/R$.

Units : SI and commercial; Power rating of common appliances, household consumption of electric energy; calculation of total energy consumed by electrical appliances; $W = Pt$ (kilowatt \times hour = kW h), [simple numerical problems].

- (iii) Household circuits – main circuit; switches; fuses; earthing; safety precautions; three-pin plugs; colour coding of wires.

House wiring (ring system), power distribution; main circuit (3 wires-live, neutral, earth) with fuse / MCB, main switch and its advantages - circuit diagram; two way switch, staircase wiring, need for earthing, fuse, 3-pin plug and socket; Conventional location of live, neutral and earth points in 3 pin plugs and sockets. Safety precautions, colour coding of wires.

- (iv) Magnetic effect of a current (principles only, laws not required); electromagnetic induction (elementary); transformer.

Oersted's experiment on the magnetic effect of electric current; magnetic field (B) and field lines due to



current in a straight wire (qualitative only), right hand thumb rule – magnetic field due to a current in a loop; Electromagnets: their uses; comparisons with a permanent magnet; Fleming’s Left Hand Rule, the DC electric motor- simple sketch of main parts (coil, magnet, split ring commutators and brushes); brief description and type of energy transfer(working not required): Simple introduction to electromagnetic induction; frequency of AC in house hold supplies , Fleming’s Right Hand Rule, AC Generator - Simple sketch of main parts, brief description and type of energy transfer(working not required). Advantage of AC over DC. Transformer- its types, characteristics of primary and secondary coils in each type (simple labelled diagram and its uses).

5. Heat

- (i) Calorimetry : meaning, specific heat capacity; principle of method of mixtures; Numerical Problems on specific heat capacity using heat loss and gain and the method of mixtures.

Heat and its units (calorie, joule), temperature and its units (°C, K); thermal (heat) capacity $C = Q/\Delta T...$ (SI unit of C): Specific heat Capacity $C = Q/m\Delta T$ (SI unit of C) Mutual relation between Heat Capacity and Specific Heat capacity, values of C for some common substances (ice, water and copper). Principle of method of mixtures including mathematical statement. Natural phenomenon involving specific heat. Consequences of high sp. heat of water. [Simple numerical problem].

- (ii) Latent heat; loss and gain of heat involving change of state for fusion only.

Change of phase (state); heating curve for water; latent heat; sp latent heat of fusion (SI unit). Simple numerical problems. Common physical phenomena involving latent heat of fusion.

6. Modern Physics

- (i) Radioactivity and changes in the nucleus; background radiation and safety precautions.

Brief introduction (qualitative only) of the nucleus, nuclear structure, atomic number (Z), mass number (A).Radioactivity as spontaneous disintegration. α , β and γ - their nature and properties; changes within the nucleus. One example each of α and β decay with equations showing changes in Z and A. Uses of radioactivity - radio isotopes. Harmful effects. Safety precautions. Background radiation.

Radiation : X-rays; radioactive fallout from nuclear plants and other sources.

Nuclear Energy : working on safe disposal of waste. Safety measures to be strictly reinforced.

- (ii) Nuclear fission and fusion; basic introduction and equations.

A NOTE ON SI UNITS

SI units (System International d’Unites) were adopted internationally in 1968.

Fundamental units : The system has seven fundamental (or basic) units, one for each of the fundamental quantities.

Fundamental quantity	Unit	
	Name	Symbol
Mass	Kilogram	kg
Length	Metre	m
Time	Second	s
Electric current	Ampere	A
Temperature	Kelvin	K
Luminous intensity	Candela	cd
Amount of substance	Mole	mol

Derived units : These are obtained from the fundamental units by multiplication or division; no numerical factors are involved. Some derived units with complex names are:

Derived quantity	Unit	
	Name	Symbol
Volume	Cubic metre	m^3
Density	Kilogram per cubic metre	$kg.m^{-3}$
Velocity	Metre per second	$m.s^{-1}$
Acceleration	Metre per second squared	$m.s^{-2}$
Momentum	Kilogram metre per second	$kg.m.s^{-1}$

Some derived units are given special names due to their complexity when expressed in terms of the fundamental units, as below:

Derived quantity	Unit	
	Name	Symbol
Force	Newton	N
Pressure	Pascal	Pa
Energy, Work	Joule	J
Power	Watt	W
Frequency	Hertz	Hz
Electric charge	Coulomb	C
Electric resistance	Ohm	Ω
Electromotive force	Volt	V

When the unit is named after a person, the symbol has a capital letter.

Standard prefixes : Decimal multiples and submultiples are attached to units when appropriate, as below:



Multiple	Prefix	Symbol
109	giga	G
106	mega	M
103	kilo	k
10-1	deci	d
10-2	centi	c
10-3	milli	m
10-6	micro	μ
10-9	nano	n
10-12	pico	p
0-15	femto	f

INTERNAL ASSESSMENT OF PRACTICAL WORK

Candidates will be asked to carry out experiments for which instructions will be given. The experiments may be based on topics that are not included in the syllabus but theoretical knowledge will not be required. A candidate will be expected to be able to follow simple instructions, to take suitable readings and to present these readings in a systematic form. He/she may be required to exhibit his/her data graphically. Candidates will be expected to appreciate and use the concepts of least count, significant figures and elementary error handling.

Note : Teachers may design their own set of experiments, preferably related to the theory syllabus. A comprehensive list is suggested below.

- Lever :** There are many possibilities with a meter rule as a lever with a load (known or unknown) suspended from a point near one end (say left), the lever itself pivoted on a knife edge, use slotted weights suspended from the other (right) side for effort.

Determine the mass of a metre rule using a spring balance or by balancing it on a knife edge at some point away from the middle and a 50g weight on the other side. Next pivot (F) the metre rule at the 40cm, 50cm and 60cm mark, each time suspending a load L or the left end and effort E near the right end. Adjust E and or its position so that the rule is balanced. Tabulate the position of L, F and E and the magnitudes of L and E and the distances of load arm and effort arm. Calculate $MA=L/E$ and $VR = \text{effort arm/load arm}$. It will be found that $MA < VR$ in one case, $MA=VR$ in another and $MA > VR$ in the third case. Try to explain why this is so. Also try to calculate the real load and real effort in these cases.

- Determine the VR and MA of a given pulley system.
- Trace the course of different rays of light refracting

through a rectangular glass slab at different angles of incidence, measure the angles of incidence, refraction and emergence. Also measure the lateral displacement.

- Determine the focal length of a convex lens by (a) the distant object method and (b) using a needle and a plane mirror.
- Determine the focal length of a convex lens by using two pins and formula $f = uv/(u+v)$.
- For a triangular prism, trace the course of rays passing through it, measure angles i_1, i_2, A and δ . Repeat for four different angles of incidence (say $i_1=40^\circ, 50^\circ, 60^\circ$ and 70°). Verify $i_1 + i_2 = A + \delta$ and $A = r_1 + r_2$.
- For a ray of light incident normally ($i_1=0$) on one face of a prism, trace course of the ray. Measure the angle δ . Explain briefly. Do this for prisms with $A=60^\circ, 45^\circ$ and 90° .
- Calculate the sp. heat of the material of the given calorimeter, from the temperature readings and masses of cold water, warm water and its mixture taken in the calorimeter.
- Determination of sp. heat of a metal by method of mixtures.
- Determination of specific latent heat of ice.
- Using a simple electric circuit, verify Ohm's law. Draw a graph, and obtain the slope.
- Set up model of household wiring including ring main circuit. Study the function of switches and fuses.

Teachers may feel free to alter or add to the above list. The students may perform about 10 experiments. Some experiments may be demonstrated.

EVALUATION

The practical work/project work are to be evaluated by the subject teacher and by an External Examiner. (The External Examiner may be a teacher nominated by the Head of the school, who could be from the faculty, **but not teaching the subject in the relevant section/class**. For example, a teacher of Physics of Class VIII may be deputed to be an External Examiner for Class X, Physics projects.)

The Internal Examiner and the External Examiner will assess the practical work/project work independently.

Award of marks (20 Marks)

- Subject Teacher (Internal Examiner) 10 marks
- External Examiner 10 marks

The total marks obtained out of 20 are to be sent to the Council by the Head of the school.

The Head of the school will be responsible for the entry of marks on the mark sheets provided by the Council.



ICSE Solved Paper, 2018

Class-X

Physics

(Maximum Marks : 80)

(Time allowed : Two hours)

- (i) Answers to this paper must be written on the paper provided separately.
(ii) You will not be allowed to write during the first 15 minutes.
(iii) This time is to be spent in reading the Question Paper.
(iv) The time given at the head of this Paper is the time allowed for writing the answers.

Section I is compulsory. Attempt any four questions from **Section II**.
The intended marks for questions or parts of questions are given in brackets [].

SECTION - I

(40 Marks)

Attempt all questions from this Section.

Question 1

- (a) (i) State and define the S.I. unit of power.
(ii) How is the unit horse power related to the S.I. unit of power? [2]
- (b) State the energy changes in the following cases while in use: [2]
- (i) An electric iron.
(ii) A ceiling fan.
- (c) The diagram below shows a lever in use: [2]

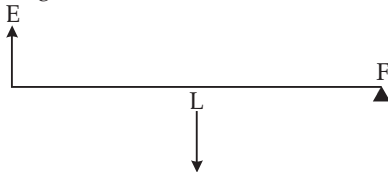

- (i) To which class of lever does it belong?
(ii) Without changing the dimensions of the lever, if the load is shifted towards the fulcrum what happens to the mechanical advantage of the lever?
- (d) (i) Why is the ratio of the velocities of light of wavelengths 4000\AA and 8000\AA in vacuum 1:1?
(ii) Which of the above wave lengths has a higher frequency? [2]
- (e) (i) Why is the motion of a body moving with a constant speed around a circular path said to be accelerated?
(ii) Name the unit of physical quantity obtained by the formula $\frac{2k}{v^2}$.

Where, K: Kinetic energy, V: Linear velocity. [2]

Question 2

- (a) The power of a lens is $-5D$ [2]
- (i) Find its focal length.
(ii) Name the type of lens.

- (b) State the position of the object in front of a converging lens if: [2]

- (i) It produces a real and same size image of the object.
(ii) It is used as a magnifying lens.

- (c) (i) State the relation between the critical angle and the absolute refractive index of a medium. [2]

- (ii) Which colour of light has a higher critical angle? Red light or Green light.

- (d) (i) Define scattering. [2]

- (ii) The smoke from a fire looks white.

Which of the following statements is true?

- Molecules of the smoke are bigger than the wavelength of light.
- Molecules of the smoke are smaller than the wavelength of light.

- (e) The following diagram shows are 60° , 30° , 90° glass prism of critical angle 42° . [2]

Copy the diagram and complete the path of incident ray AB emerging out of the prism marking the angle of incidence on each surface.

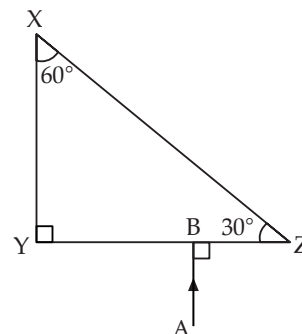

Question 3

- (a) Displacement distance graph of two sound waves A and B, travelling in a medium, are shown in the diagram below. [2]

To know about more useful books for class-10 [click here](#)

Displacement (cm)

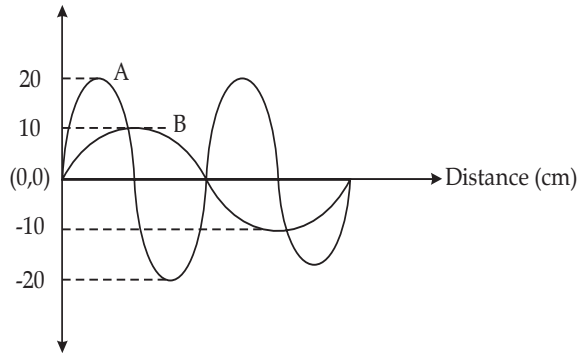

Study the two sound waves and compare their :

- (i) Amplitudes
(ii) Wavelengths
- (b) You have three resistors of values 2Ω , 3Ω and 5Ω . How will you join them so that the total resistance is more than 7Ω ? [2]
- (i) Draw a diagram for the arrangement.
(ii) Calculate the equivalent resistance.
- (c) (i) What do you understand by the term nuclear fusion? [2]
(ii) Nuclear power plants use **nuclear fission** reaction to produce electricity. What is the advantage of producing electricity by **fusion** reaction?
- (d) (i) What do you understand by free vibrations of body? [2]

- (ii) Why does the amplitude of a vibrating body continuously decrease during damped vibrations?
- (e) (i) How is the e.m.f. across primary and secondary coils of a transformer related with the number of turns of coil in them? [2]
(ii) On which type of current do transformers work?

Question 4

- (a) (i) How can a temperature in degree Celsius be converted into S.I. unit of temperature? [2]
(ii) A liquid X has the maximum specific heat capacity and is used as a coolant in Car radiators. Name the liquid X.
- (b) A solid metal weighing 150 g melts at its melting point of 800°C by providing heat at the rate of 100 W. The time taken for it to completely melt at the same temperature is 4 min. What is the specific latent heat of fusion of the metal? [2]
- (c) Identify the following wires used in a household circuit: [2]
(i) The wire is also called as the phase wire.
(ii) The wire is connected to the top terminal of a three pin socket.
- (d) (i) What are isobars? [2]
(ii) Give one example of isobars.
- (e) State any two advantages of electromagnets over permanent magnets. [2]

SECTION - II

(40 Marks)

*Attempt any four questions from this Section.***Question 5**

- (a) (i) Derive a relationship between S.I. and C.G.S. unit of work. [3]
(ii) A force acts on body and displaces it by a distance S in a direction at an angle θ with the direction of force. What should be the value of θ to get the maximum positive work?
- (b) A half metre rod is pivoted at the centre with two weights of 20 gf and 12 gf suspended at a perpendicular distance of 6 cm and 10 cm from the pivot respectively as shown below. [3]

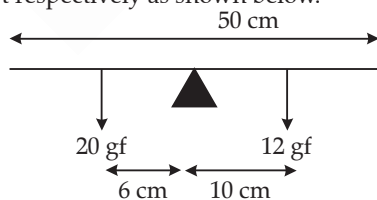

- (i) Which of the two forces acting on the rigid rod causes clockwise moment?
(ii) Is the rod in equilibrium?
(iii) The direction of 20 kgf force is reversed. What is the magnitude of the resultant moment of the

forces on the rod?

- (c) (i) Draw a diagram to show a block and tackle pulley system having a velocity ratio of 3 marking the direction of load (L), effort (E) and tension (T). [4]
(ii) The pulley system drawn lifts a load of 150 N when an effort of 60 N is applied. Find its mechanical advantage.
(iii) Is the above pulley system an ideal machine or not?

Question 6

- (a) A ray of light XY passes through a right angled isosceles prism as shown below. [3]

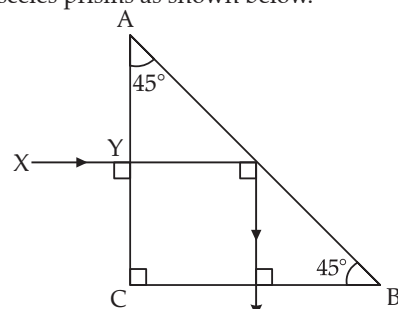

To know about more useful books for class-10 [click here](#)

- (i) What is the angle through which the incident ray deviates and emerges out of the prism?
 (ii) Name the instrument where this action of prism is put into use.
 (iii) Which prism surface will behave as a mirror?

- (b) An object AB is placed between O and F_1 on the principal axis of a converging lens as shown in the diagram. [3]

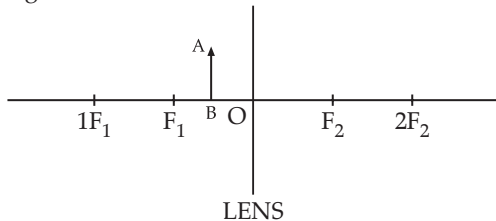

Copy the diagram and by using three standard rays starting from point A, obtain an image of the object AB.

- (c) An object is placed at a distance of 12 cm from a convex lens of focal length 8 cm. Find: [4]
 (i) the position of the image.
 (ii) nature of the image

Question 7

- (a) Draw the diagram of a right angled isosceles prism which is used to make an inverted Image erect. [3]
 (b) [3]

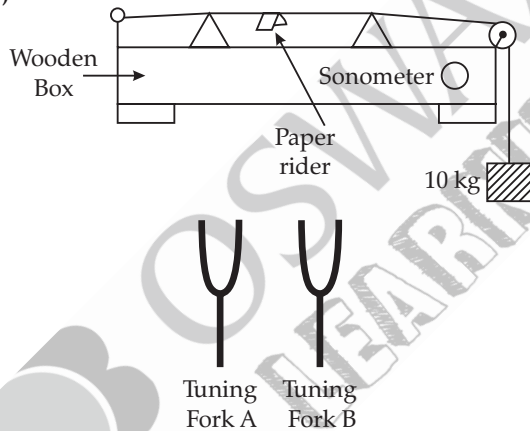

The diagram above shows a wire stretched over a sonometer. Stems of two vibrating tuning forks A and B are touched to the wooden box of the sonometer. It is observed that the paper rider (a small piece of paper folded at the centre) present on the wire flies off when the stem of vibrating tuning fork B is touched to the wooden box.

- (i) Name the phenomenon when the paper rider just vibrates.
 (ii) Name the phenomenon when the paper rider flies off.
 (iii) Why does the paper rider fly off when the stem of tuning fork B is touched to the box?
 (c) A person is standing at the sea shore. An observer on the ship which is anchored in between a vertical

cliff and the person on the shore fires a gun. The person on the shore hears two sounds, 2 seconds and 3 seconds after seeing the smoke of the fired gun. If the speed of sound in the air is 320 ms^{-1} then calculate: [4]

- (i) The distance between the observer on the ship and the person on the shore.
 (ii) The distance between the cliff and the observer on the ship.

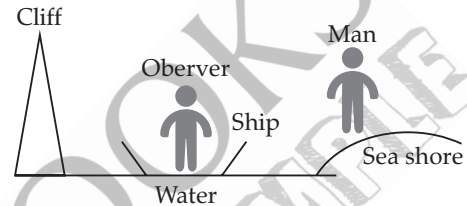

Question 8

- (a) (i) A fuse is rated 8 A. Can it be used with an electrical appliance rated 5 KW, 200 V? Give a reason. [3]
 (ii) Name two safety devices which are connected to the live wire of household electric circuit.
- (b) (i) Find the equivalent resistance between A and B.

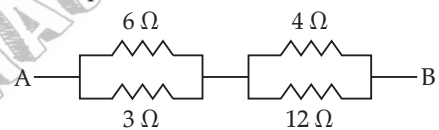

- (ii) State whether the resistivity of a wire changes with the change in the thickness of the wire.
 (c) An electric iron is rated 220V, 2KW. [4]
 (i) If the iron is used for 2h daily find the cost of running it for one week if it costs ₹4.25 per kWh.
 (ii) Why is the fuse absolutely necessary in a power circuit?

Question 9

- (a) (i) Heat supplied to a solid changes it into liquid. What is this change in phase called? [3]
 (ii) During the phase change does the average kinetic energy of the molecules of the substance increase?
 (iii) What is the energy absorbed during the phase change called?
 (b) (i) State two differences between "Heat Capacity" and "Specific Heat Capacity". [3]
 (ii) Give a mathematical relation between Heat Capacity and Specific Heat Capacity.
 (c) The temperature of 170g of water 50°C is lowered to 5°C by adding certain amount of ice to it. Find the mass of ice added. [4]

Given :

Specific heat capacity of water = $4200 \text{ kg}^{-1} \text{ }^\circ\text{C}^{-1}$
 and Specific latent heat of ice = 336000 J kg^{-1}

Question 10

(a)

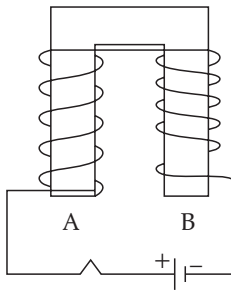

[3]

The diagram shows a coil wound around a U shape soft iron bar AB.

- (i) What is the polarity induced at the ends A and B when the switch is pressed?
 - (ii) Suggest one way to strengthen the magnetic field in the electromagnet.
 - (iii) What will be the polarities at A and B if the direction of current is reversed in the circuit?
- (b) The ore of Uranium found in nature contains ^{238}U and ^{235}U . Although both the Isotopes are fissionable, it is found out experimentally that one of the two isotopes is more easily fissionable. [3]
- (i) Name the isotope of Uranium which is easily fissionable.
 - (ii) Give a reason for your answer.

(iii) Write a nuclear reaction when Uranium 238 emits an alpha particle to form a Thorium (Th) nucleus.

- (c) Radiations given out from a source when subjected to an electric field in a direction perpendicular to their path are shown below in the diagram. The arrows show the path of the radiation A, B and C. Answer the following questions in terms of A, B and C. [4]

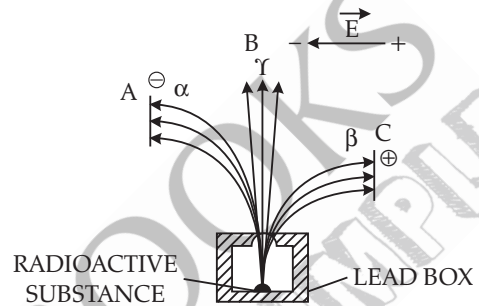

- (i) Name the radiation B which is unaffected by the electric field.
- (ii) Why does the radiation C deflect more than A?
- (iii) Which among the three causes the least biological damage externally?
- (iv) Name the radiation which is used in carbon dating.

□□

SOLUTIONS

SECTION - I

(40 Marks)

1. (a) (i) The rate at which work is done by a force is called the power i.e $P = \frac{W}{t}$

The S.I. unit of power is watt (w),
1 watt is defined as 1 Joule/second

- (ii) Another unit of power is horse power (H.P)
1 horse power = 746 watt
- (b) (i) In electric iron, the electrical energy changes into heat energy.
- (ii) In ceiling fan, the electrical energy changes into mechanical energy of rotation.
- (c) (i) Lever shown in figure is Class 2 lever as Load L is in between Effort E and Fulcrum F.

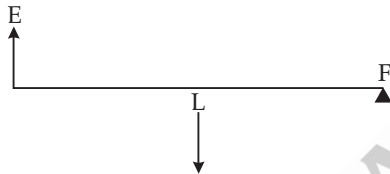

- (ii) If load is shifted towards fulcrum, Then mechanical advantage increases as mechanical advantages is defined as the ratio of effort Arm to Load Arm i.e.

$$\text{Mechanical advantage} = \frac{\text{Effort Arm}}{\text{Load Arm}} = \frac{\text{Load}}{\text{Effort}}$$

- (d) (i) Ratio of velocity of light $\lambda = 4000 \text{ \AA}$ & 8000 \AA in vacuum is in ratio of 1:1, because velocity does not depend on λ .
- (ii) Since we have $v = f\lambda \Rightarrow f = \frac{v}{\lambda}$
 \Rightarrow Smaller λ have higher frequency
 $\Rightarrow \lambda = 4000 \text{ \AA}$ have higher frequency
- (e) (i) Motion around the circular path is said to be accelerated because there is a acceleration in motion as velocity changes in direction with constant speed.
- (ii) If $K \rightarrow$ kinetic energy, $v \rightarrow$ Linear Velocity

$$\text{then unit of } \frac{2K}{v^2} = \frac{2 \cdot \frac{1}{2} m v^2}{v^2} = m(\text{mass})$$

ie, obtained physical quantity in mass has SI unit in Kg

2. (a) Given Power $P = -5D$

(i) Focal length $F = \frac{1}{p} = -\frac{1}{5} \text{ meter} = -20 \text{ cm}$

(ii) Since power is $-ve$, the lens is diverging lens.

- (b) (i) When object is placed at $2f$, then converging lens produce real and same size image

- (ii) When object is placed in between f & O of lens then converging lens is used as magnifying lens.

- (c) (i) If critical angle is i_c and refractive index is μ then from law of refraction

$$\mu \sin i_c = 1 \cdot \sin 90^\circ$$

$$\Rightarrow \mu = \frac{1}{\sin i_c}$$

(\because for Total internal reflection $r = 90^\circ$)

- (ii) Since the velocity of light for red is more than green. So, refractive index of red will be smaller (as $\mu \propto \frac{1}{v}$).

Again critical angle for green will be smaller than red because $\sin i_c = \frac{1}{\mu}$. ie, $\mu_R < \mu_g \Rightarrow i_{Rc} > i_{gc}$.
Hence, critical angle for red light will be greater than green light.

- (d) (i) **Scattering** : The phenomenon of bending of light at the corners of small object and aparatures is called scattering. It is determine by Rayleigh's law of scattering, defined by

$$I_\lambda \propto \frac{1}{\lambda^4} \text{ where size of obstacle / aperture is}$$

$$a \ll \lambda$$

- (ii) Smoke from fire looks white due to scattering from smoke molecules therefore for scattering molecule of smoke are bigger than λ of light, so option (1) is true.

- (e) Since critical angle of prism

$i_c = 42^\circ$, for given ray AB the incidence angle is 30° , therefore ray AB incident on surface YZ at angle of incidence of 30° and refracted out from

prism ($\because \mu = \frac{1}{\sin i_c}$). The angle of refraction is given by

$$\begin{aligned} \mu \sin i &= 1 \cdot \sin r \Rightarrow \sin r = \frac{\mu \sin i}{1} \\ &= \frac{\sin 30^\circ}{\sin 42^\circ} = \frac{0.5}{0.669} = 0.75 \end{aligned}$$

$$\Rightarrow r = 40^\circ$$

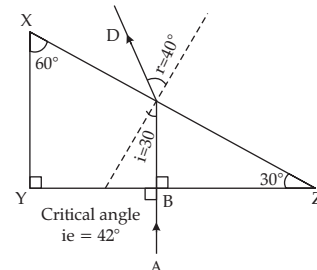

3. (a) (i) Amplitude of Sound A is larger than Sound B because Amplitude of $A = 20 \text{ cm} >$ Amplitude of $B = 10 \text{ cm}$
 (ii) Wavelength of Sound A and B is given by $\lambda_B = 2\lambda_A$

$$\Rightarrow \lambda_A = \frac{\lambda_B}{2}$$

so $\lambda_A : \lambda_B = 1 : 2$

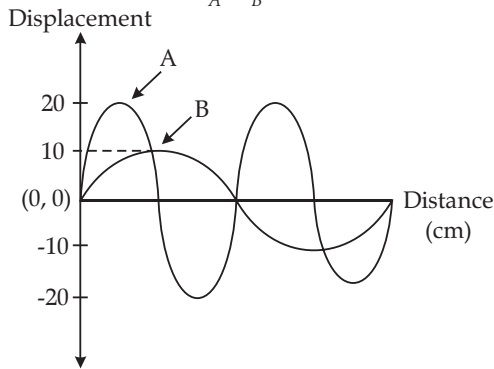

- (b) (i) $A \text{---} 2\Omega \text{---} 3\Omega \text{---} 5\Omega \text{---} B$
 (ii) $R_{\text{equivalent}} = R_1 + R_2 + R_2 = 2 + 3 + 5 = 10 \Omega$
 (c) (i) **Nuclear fusion** : When two or more smaller nuclei produce the bigger nuclei by releasing large amount of energy, the process is called Nuclear fusion. e.g.
 ${}_1\text{H}^2 + {}_1\text{H}^2 \rightarrow {}_2\text{He}^3 + \text{on}^1 + \text{energy}$.
 (ii) Advantages on producing electricity by Nuclear fusion are:
 (1) No toxic waste are produced.
 (2) No radioactive radiation produced.
 (3) Nuclear fusion power plant can be located near the populated areas.
 (4) We produce large amount of energy by consuming simple Hydrogen gas.
 (d) (i) When a body is vibrating freely with constant amplitude of oscillation is called free vibration of a body.

- (ii) When there is a damping force acting on vibrating body, then amplitude of vibration decreases due to damping force such vibration is called damped vibration.

- (e) (i) If N_p and N_s are number of turns in primary and secondary coil of transformer and E_p and E_s are the emf is primary and secondary coils than we have

$$\frac{E_p}{E_s} = \frac{N_p}{N_s}$$

- (ii) We use alternating current A.C. in Transformers.

4. (a) (i) The S.I. unit of Temperature is K. We convert $^{\circ}\text{C}$ to K by adding 273.

$$\rightarrow K = ^{\circ}\text{C} + 273$$

- (ii) The liquid X is water used as coolant in car.

- (b) Given $m = 150 \text{ g} = 0.15 \text{ kg}$, Heat Rate $R = 100 \text{ W}$
 time $t = 4 \text{ min} = 4 \times 60 \text{ s} = 240 \text{ s}$.

Let L is the latent heat of metal, we know that

$$mL = P \cdot \Delta t$$

$$\rightarrow L = p \cdot \Delta t / m = 100 \times 4 \times 60 / 0.15 = 1.6 \times 10^5 \text{ J/kg}$$

- (c) (i) Red wire is used as phase wire
 (ii) Green earth wire is connected to top of three pin plug.
 (d) (i) **Isobar** : The atoms which have same mass number A but different atomic number Z is called Isobars.

- (ii) Example of Isobar

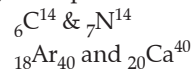

- (e) **Two advantages of electromagnet over permanent magnets are :**

- (1) Electromagnet can be easily ON and OFF
 (2) Magnetic field B can be controlled by controlling the current flowing in electromagnet.
 (3) These can be used in medical science.

SECTION - II

(40 Marks)

5. (a) (i) Work done = force \times displacement
 The S.I. unit of work is Joule or Newton meter and CGS unit of work is erg or dyne x cm.
 $\rightarrow 1 \text{ joule} = 1 \text{ N} \times 1 \text{ m} = 10^5 \text{ dyne} \times 10^2 \text{ cm} = 10^7 \text{ ergs}$.
 (ii) we know work done $w = F_S \cos \theta$
 To get maximum the work done, θ is 0 (zero)
 \rightarrow angle b/w force and displacement θ is zero.
 (b) (i) 12gf force produce clockwise 50 cm motion.

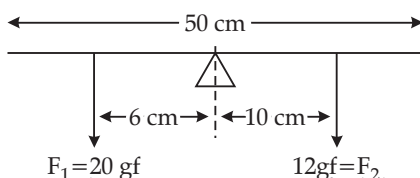

- (ii) Moment of $F_1 = 20 \text{ gf} \times 6 \text{ cm}$

$$F_1 = 20 \text{ gf}$$

$$= 120 \text{ gf cm.}$$

$$\text{Moment of } F_2 = 12 \text{ gf} \times 10 \text{ cm} = 120 \text{ gfcm}$$

$$\text{Since moment of } F_1 = \text{moment of } F_2$$

\rightarrow rod is in equilibrium

- (iii) If direction of 20gf is reverse, the resultant moment of force on rod is

$$T = 120 \text{ gfcm} + 120 \text{ gf cm} = 240 \text{ gfcm.}$$

- (c) (i) Pulley system diagram is shown in figure. Labelled tension T, load L and effort E.
 (ii) The mechanical advantage of pulley system is given by load/effort
 Given load $L = 150 \text{ N}$, Effort $E = 60 \text{ N}$
 \rightarrow Mechanical Advantage = $L/E = 150/60 = 2.5$

To know about more useful books for class-10 [click here](#)

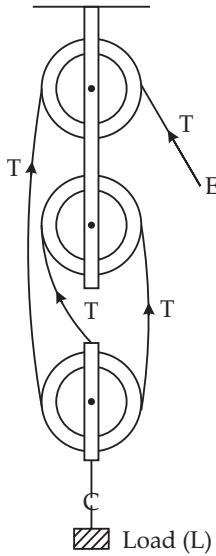

(iii) The above pulley system is not an ideal machine because there must be some friction.

6. (a) (i) The angle of deviation between incident and emerging out ray from prism is $S = 90^\circ$

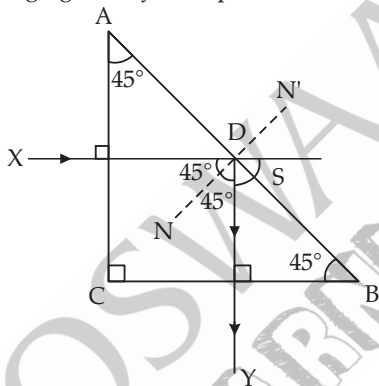

(ii) This action of prism is used perfect reflector the instrument called the instrument called periscope.

(iii) The Prism Surface AB act is mirror.

- (b) (i) Fig. shows the ray diagram using three rays started from point A, we get the image A'B'

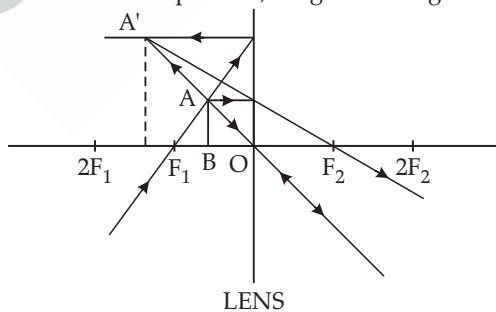

- (c) Given object distance $u = -12$ cm, Focal length $f = 8$ cm.

We know lense formula $\frac{1}{f} = \frac{1}{v} - \frac{1}{u}$

$$\text{or, } \frac{1}{v} = \frac{1}{f} + \frac{1}{u} = \frac{1}{8} - \frac{1}{12} = \frac{3-2}{24} = \frac{1}{24}$$

or, $v = +24$ cm

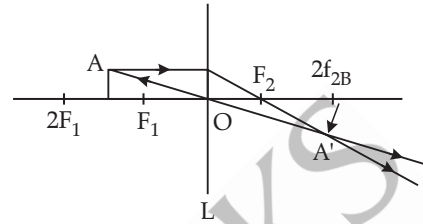

- (i) Position of image $V = +24$ cm., Right side of lense
 (ii) Nature of image is Real, inverted and magnified.

7. (a) Diagram is shown in figure for inverted erect image by Right angle isosceles prism.

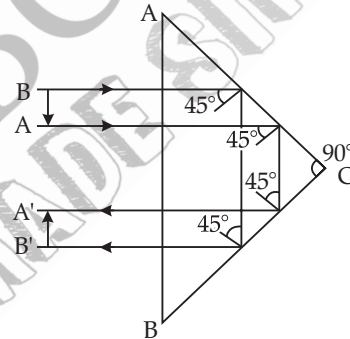

- (b) (i) When paper just vibrate on the wire of sonometer then phenomenon is called 1st overtone or 2nd harmonics.
 (ii) When paper flies off, then we have fundamental mode or first harmonics.
 (iii) Paper files off by Tuning Fork B, because it produce fundamental mode or first harmonics in wire.

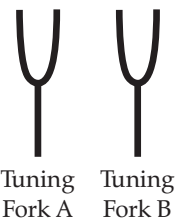
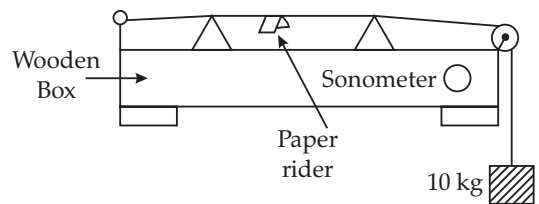

- (c) Given $V = 320 \text{ ms}^{-1}$
 Sea Shore man listen two sounds in $t_1 = 2$ sec and $t_2 = 3$ sec after seeing smoke.

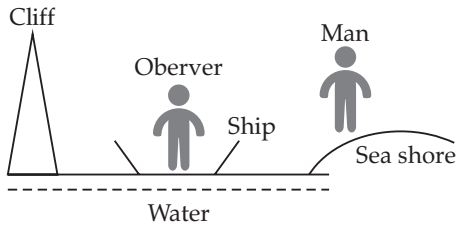

- (i) Since, sea shore man listen one sound in 2 Sec which comes back from observer, so distance between observer and man on shore is

$$\frac{320 \times 2}{2} \text{ m,}$$

$$d_1 = 320 \text{ m}$$

- (ii) Since Sea Shore man listen other sound in 3 second by reflecting from cliff. So distance b/w cliff and sea shore man is

$$d_2 = \frac{320 \times 3}{2}$$

Thus the distance b/w cliff F observer on ship is $d = d_2 - d_1 = 480 - 320 = 160 \text{ m}$

8. (a) (i) For given appliance $P = 5 \text{ KW}$, $V = 200 \text{ V}$

$$\Rightarrow I = \frac{P}{V} = \frac{5 \times 1000}{200} = 25 \text{ A}$$

Since given fuse is rated $I_{\text{fuse}} = 8 \text{ A}$ which is less than 25 A , thus we can not use this fuse in given appliance.

- (ii) **Two safety device used in live wire are :**

- (1) Switches (2) Fuse

- (b) (i)

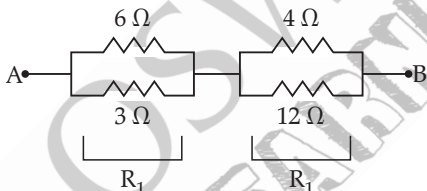

$$R_{\text{eq}} = R_1 + R_2$$

$$R_1 = \frac{6 \times 3}{6 + 3} = \frac{18}{9} = 2\Omega$$

$$R_2 = \frac{4 \times 12}{4 + 12} = \frac{48}{16} = 3\Omega$$

$$R_{AB} = R_{\text{eq}} = R_1 + R_2 = 2\Omega + 3\Omega = 5\Omega$$

- (ii) Resistivity ρ does not changes with thickness of wire, since it is independent of dimension of wire but it depends on material only.
- (c) (i) Given electric irons rated 220 V , 2 KW daily uses 2 hr , Cost = ₹ $4.25 / \text{kWh}$
 \Rightarrow Cost of power used by Iron for one week
 $= 7 \text{ day} \times 2 \text{ hr} \times 2 \text{ kW} \times ₹ 4.25 / \text{KWhr.}$
 $= ₹ 28 \times 4.25 = ₹ 119.00$

- (ii) Fuse is necessary in electrical circuit because if there is a flow of high current or voltage in the circuit, then fuse is blown off by melting and as a result the power circuit of OFF and our appliance are safe and they are protected.

9. (a) (i) When solid changed into liquid by supply heat, this change in phase is called melting.
 (ii) During this phase change K.E. of molecules of substance increases .
 (iii) The energy observed during this phase change is called latent heat of solid.

- (b) (i) Difference between heat capacity and specific heat capacity

$$(1) \text{ Heat capacity } c = \frac{Q}{\Delta T},$$

$$\text{Specific heat capacity } s = \frac{Q}{m\Delta T}$$

- (2) Unit of heat capacity is J°C while of specific heat capacity is $\text{J}/\text{kg}^\circ\text{C}$

$$(ii) \text{ Since heat capacity } c = \frac{Q}{\Delta T},$$

$$\text{Sp. Heat Capacity } s = \frac{Q}{m\Delta T}$$

$$\Rightarrow \text{Specific heat capacity } s = \frac{Q}{m\Delta T} = \frac{1}{m}$$

(heat capacity)

\Rightarrow heat capacity = mass \times specific heat capacity

- (c) **Given** mass of water = $170 \text{ g} = 0.17 \text{ kg}$

$$T_1 = 50^\circ\text{C}, T_2 = 5^\circ\text{C},$$

specific heat capacity of water = $4200 \text{ J kg}^{-1}\text{C}^{-1}$

Sp. Latent heat of ice = 336000 J kg^{-1}

Let mass of ice added be x then we have heat lost by water = Heat used by ice.

\Rightarrow water at 50°C to 5°C = ice at $^\circ\text{C}$ to water at $^\circ\text{C}$ + water at 0°C to 5°C

$$\Rightarrow 0.17 \times 4200 \times (50 - 5)$$

$$= x \times 336000 + x \times 4200 \times 5 = 32130$$

$$= 357000x$$

$$\text{or, } x = \frac{32130}{357000}$$

$$= 0.09 \text{ Kg}$$

$$x = 90 \text{ g}$$

\Rightarrow we should add 90 g of ice to water.

10. (a) (i) Fig. shows U shaped soft iron bar AB when switch is pressed, current flows in coils and soft iron becomes electromagnet, From Right hand thumb rule, the polarity of A and B be South Pole (S)

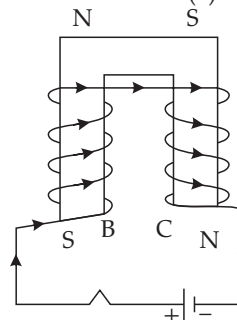

- (ii) To strengthen the \vec{B} in electromagnet, we use the cross wire in bar A and B or by increasing the current in coils. Fig. Shows coils.

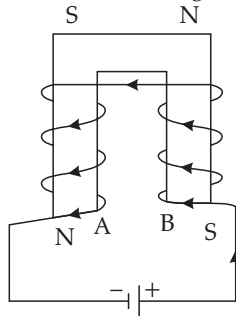

- (iii) If direction of current is reverse in arrangement (i) the ends A and B will act as North Pole (N).
- (b) (i) The isotope ${}_{92}\text{U}^{235}$ is more easily fissionable.
 (ii) Because this nuclei ${}_{92}\text{U}^{235}$ is fissioned by thermal neutrons and converted to ${}_{92}\text{U}^{236}$ as then ${}_{92}\text{U}^{236} + {}_0\text{n}^1 \rightarrow {}_{92}\text{U}^{236} \rightarrow {}_{56}\text{Ba}^{144} + {}_{36}\text{Kr}^{89} + 3{}_0\text{n}^1 + 200 \text{ Mev}$. Breaks up to Ba and Kr and neutron and release large amount of energy.

Nuclear reaction of ${}_{92}\text{U}^{238}$ emits α particle as

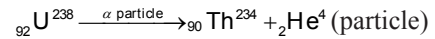

- (c) (i) Radiation B is γ -Ray, which is undeflected in electric field.
 (ii) The Radiation C is deflected more than A because they have light mass (β particle) then the particle A (He nucleus)

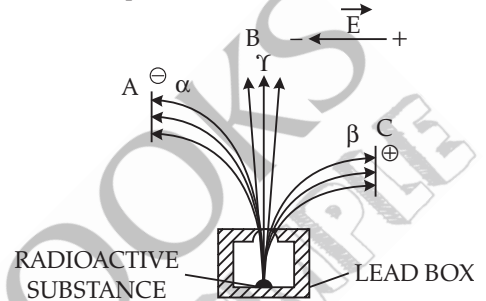

- (iii) α particle causes least biological damage because they are loosely penetrating particle.
 (iv) β particle or radiation is used in carbon dating.

□□