

SUBJECT : PHYSICS	DAY - 2
SESSION : MORNING	TIME : 10.30 A.M. TO 11.50 A.M.

MAXIMUM MARKS	TOTAL DURATION	MAXIMUM TIME FOR ANSWERING
60	80 MINUTES	70 MINUTES

MENTION YOUR CET NUMBER	QUESTION BOOKLET DETAILS	
	VERSION CODE	SERIAL NUMBER
	A - 1	472657

DOs :

1. Check whether the CET No. has been entered and shaded in the respective circles on the OMR answer sheet.
2. This Question Booklet is issued to you by the invigilator after the 2nd Bell i.e., after 10.30 a.m.
3. The Serial Number of this question booklet should be entered on the OMR answer sheet.
4. The Version Code of this question booklet should be entered on the OMR answer sheet and the respective circles should also be shaded completely.
5. Compulsorily sign at the bottom portion of the OMR answer sheet in the space provided.

DON'TS :

1. **THE TIMING AND MARKS PRINTED ON THE OMR ANSWER SHEET SHOULD NOT BE DAMAGED / MUTILATED / SPOILED.**
2. **The 3rd Bell rings at 10.40 a.m., till then;**
 - Do not remove the paper seal present on the right hand side of this question booklet.
 - Do not look inside this question booklet.
 - Do not start answering on the OMR answer sheet.

IMPORTANT INSTRUCTIONS TO CANDIDATES

1. This question booklet contains 60 questions and each question will have one statement and four distracters. (Four different options / choices.)
2. After the 3rd Bell is rung at 10.40 a.m., remove the paper seal on the right hand side of this question booklet and check that this booklet does not have any unprinted or torn or missing pages or items etc., if so, get it replaced by a complete test booklet. Read each item and start answering on the OMR answer sheet.
3. During the subsequent 70 minutes:
 - Read each question carefully.
 - Choose the correct answer from out of the four available distracters (options / choices) given under each question / statement.
 - **Completely darken / shade the relevant circle with a BLUE OR BLACK INK BALL POINT PEN against the question number on the OMR answer sheet.**

Correct Method of shading the circle on the OMR answer sheet is as shown below :



4. Please note that even a minute unintended ink dot on the OMR answer sheet will also be recognised and recorded by the scanner. Therefore, avoid multiple markings of any kind on the OMR answer sheet.
5. Use the space provided on each page of the question booklet for Rough Work. Do not use the OMR answer sheet for the same.
6. After the last bell is rung at 11.50 a.m., stop writing on the OMR answer sheet and affix your LEFT HAND THUMB IMPRESSION on the OMR answer sheet as per the instructions.
7. Hand over the OMR ANSWER SHEET to the room invigilator as it is.
8. After separating the top sheet (Our Copy), the invigilator will return the bottom sheet replica (Candidate's copy) to you to carry home for self-evaluation.
9. Preserve the replica of the OMR answer sheet for a minimum period of ONE year.

SEAL

1. Which one of the following is NOT correct ?
 - (1) Dimensional formula of thermal conductivity (K) is $M^1L^1T^{-3}K^{-1}$
 - (2) Dimensional formula of potential (V) is $M^1L^2T^3A^{-1}$
 - (3) Dimensional formula of permeability of free space (μ_0) is $M^1L^1T^{-2}A^{-2}$
 - (4) Dimensional formula of RC is $M^0L^0T^{-1}$

2. In a lift moving up with an acceleration of 5 ms^{-2} , a ball is dropped from a height of 1.25 m. The time taken by the ball to reach the floor of the lift is (nearly) ($g = 10 \text{ ms}^{-2}$)
 - (1) 0.3 second
 - (2) 0.2 second
 - (3) 0.16 second
 - (4) 0.4 second

3. A gun fires a small bullet with kinetic energy K. Then kinetic energy of the gun while recoiling is
 - (1) K
 - (2) more than K
 - (3) less than K
 - (4) \sqrt{K}

4. From a fixed support, two small identical spheres are suspended by means of strings of length 1 m each. They are pulled aside as shown and then released. B is the mean position. Then the two spheres collide,

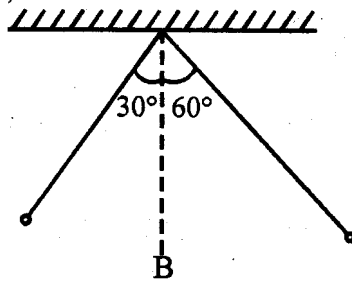

- (1) at B after 0.25 second
- (2) at B after 0.5 second
- (3) on the right side of B after some time
- (4) on the right side of B when the strings are inclined at 15° with B

Space For Rough Work

5. A truck accelerates from speed v to $2v$. Work done in during this is
- (1) three times as the work done in accelerating it from rest to v .
 - (2) same as the work done in accelerating it from rest to v .
 - (3) four times as the work done in accelerating it from rest to v .
 - (4) less than the work done in accelerating it from rest to v .
6. Earth is moving around the Sun in elliptical orbit as shown. The ratio of OB and OA is R . Then the ratio of Earth at A and B is

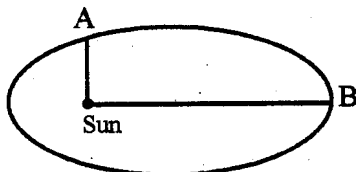

- (1) R^{-1}
 - (2) \sqrt{R}
 - (3) R
 - (4) $R^{2/3}$
7. A projectile is projected at 10 ms^{-1} by making at an angle 60° to the horizontal. After some time its velocity makes an angle of 30° to the horizontal. Its speed at this instant is
- (1) $\frac{10}{\sqrt{3}}$
 - (2) $10\sqrt{3}$
 - (3) $\frac{5}{\sqrt{3}}$
 - (4) $5\sqrt{3}$
8. For which combination of working temperatures of source and sink, the efficiency of Carnot's heat engine is maximum ?
- (1) 600 K, 400 K
 - (2) 400 K, 200 K
 - (3) 500 K, 300 K
 - (4) 300 K, 100 K

Space For Rough Work

9. A solid cylinder of radius R made of a material of thermal conductivity K_1 is surrounded by a cylindrical shell of inner radius R and outer radius $2R$ made of a material of thermal conductivity K_2 . The two ends of the combined system are maintained at two different temperatures. Then there is no loss of heat across the cylindrical surface and the system is in steady state. The effective thermal conductivity of the system is
- (1) $K_1 + K_2$ (2) $\frac{K_1 K_2}{K_1 + K_2}$
 (3) $\frac{3K_1 + K_2}{4}$ (4) $\frac{K_1 + 3K_2}{4}$
10. Two stars A and B radiate maximum energy at the wavelengths of 360 nm and 480 nm respectively. Then the ratio of the surface temperatures of A and B is
- (1) 3 : 4 (2) 81 : 256
 (3) 4 : 3 (4) 256 : 81
11. Two solids P and Q float in water. It is observed that P floats with half of its volume immersed and Q floats with $\frac{2}{3}$ rd of its volume is immersed. The ratio of densities of P and Q is
- (1) 4/3 (2) 3/4
 (3) 2/3 (4) 3/2
12. The equation of a transverse wave is given by $y = 0.05 \sin \pi(2t - 0.02x)$, where x, y are in metre and t is in second. The minimum distance of separation between two particles which are in phase and the wave velocity are respectively _____
- (1) 50 m, 50 ms^{-1} (2) 100 m, 100 ms^{-1}
 (3) 50 m, 100 ms^{-1} (4) 100 m, 50 ms^{-1}
13. The frequency of the second overtone of the open pipe is equal to the frequency of the first overtone of the closed pipe. The ratio of the lengths of the open pipe and the closed pipe is
- (1) 2 : 1 (2) 1 : 2
 (3) 1 : 3 (4) 3 : 1

Space For Rough Work

14. A person with vibrating tuning fork of frequency 338 Hz is moving towards a vertical wall with a speed of 2 ms^{-1} . Velocity of sound in air is 340 ms^{-1} . The number of beats heard by that person per second is

- (1) 2 (2) 4
(3) 6 (4) 8

15. Pick out the WRONG statement from the following :

- (1) Lateral shift increases as the angle of incidence increases.
(2) Lateral shift increases as the value of refractive index increases.
(3) Normal shift decreases as the value of refractive index increases.
(4) Both normal shift and lateral shift are directly proportional to the thickness of the medium.

16. The refraction through the prisms are as shown. Pick out the WRONG statement from the following. Path of the light ray in

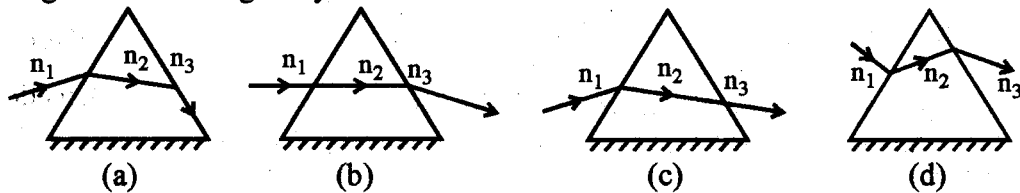

- (1) a is correct if $n_2 > n_1$ and $n_2 > n_3$
(2) b is correct if $n_1 = n_2$ and $n_2 > n_3$
(3) c is correct if $n_2 < n_1$ and $n_2 = n_3$
(4) d is correct if $n_1 > n_2$ and $n_2 < n_3$

17. The distance between an object and its real image produced by a converging lens is 0.72 m. The magnification is 2. What will be the magnification when the object is moved by 0.04 m towards the lens ?

- (1) 2 (2) 4
(3) 3 (4) 6

Space For Rough Work

18. The speed of light in media M_1 and M_2 are $1.5 \times 10^8 \text{ ms}^{-1}$ and $2 \times 10^8 \text{ ms}^{-1}$ respectively. A ray travels from medium M_1 to the medium M_2 with an angle of incidence θ . The ray suffers total internal reflection. Then the value of the angle of incidence θ is

- (1) $> \sin^{-1}\left(\frac{3}{4}\right)$ (2) $< \sin^{-1}\left(\frac{3}{4}\right)$
 (3) $= \sin^{-1}\left(\frac{4}{3}\right)$ (4) $\leq \sin^{-1}\left(\frac{3}{4}\right)$

19. Which of the following phenomena support the wave theory of light ?

- (a) scattering
 (b) interference
 (c) diffraction
 (d) velocity of light in a denser medium is less than the velocity of light in the rarer medium

- (1) a, b, c (2) a, b, d
 (3) b, c, d (4) a, c, d

20. White light reflected from a soap film (Refractive Index = 1.5) has a maxima at 600 nm and a minima at 450 nm with no minimum in between. Then the thickness of the film is _____ $\times 10^{-7}$ m.

- (1) 1 (2) 2
 (3) 3 (4) 4

21. A cylindrical tube of length 0.2 m and radius R with sugar solution of concentration 'C' produce a rotation of θ in the plane of vibration of a plane polarized light. The same sugar solution is transferred to another tube of length 0.3 m of same radius. The remaining gap is filled by distilled water. Now the optical rotation produced is

- (1) θ (2) $\frac{\theta}{3}$
 (3) $3\frac{\theta}{2}$ (4) $9\frac{\theta}{4}$

Space For Rough Work

22. Radii of curvature of a converging lens are in the ratio 1 : 2. Its focal length is 6 cm and refractive index is 1.5. Then its radii of curvature are _____ respectively.
- (1) 9 cm and 18 cm (2) 6 cm and 12 cm
(3) 3 cm and 6 cm (4) 4.5 cm and 9 cm
23. A small oil drop of mass 10^{-6} kg is hanging in at rest between two plates separated by 1 mm having a potential difference of 500 V. The charge on the drop is _____ ($g = 10 \text{ ms}^{-2}$)
- (1) 2×10^{-9} C (2) 2×10^{-11} C
(3) 2×10^{-6} C (4) 2×10^{-8} C
24. A uniform electric field in the plane of the paper as shown. Here A, B, C, D are the points on the circle. V_1, V_2, V_3, V_4 are the potentials at those points respectively. Then

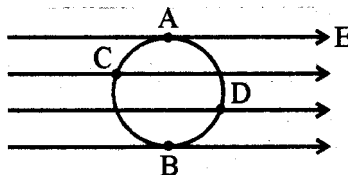

- (1) $V_A = V_C, V_B = V_D$ (2) $V_A = V_C, V_B > V_D$
(3) $V_A > V_C, V_B > V_D$ (4) $V_A = V_B, V_C = V_D$
25. Two metal spheres of radii 0.01 m and 0.02 m are given a charge of 15 mC and 45 mC respectively. They are then connected by a wire. The final charge on the first sphere is _____ $\times 10^{-3}$ C.
- (1) 40 (2) 30
(3) 20 (4) 10
26. Two concentric spheres of radii R and r have positive charges q_1 and q_2 with equal surface charge densities. What is the electric potential at their common centre ?
- (1) $\frac{\sigma}{\epsilon_0} (R + r)$ (2) $\frac{\sigma}{\epsilon_0} (R - r)$
(3) $\frac{\sigma}{\epsilon_0} \left(\frac{1}{R} + \frac{1}{r} \right)$ (4) $\frac{\sigma}{\epsilon_0} \left(\frac{R}{r} \right)$

Space For Rough Work

27. When an additional charge of 2C is given to a capacitor, energy stored in it is increased by 21% . The original charge of the capacitor is
- (1) 30C (2) 40C
 (3) 10C (4) 20C

28. When a potential difference of 10^3V is applied between A and B, a charge of 0.75mC is stored in the system of capacitors as shown. The value of C is (in μF)

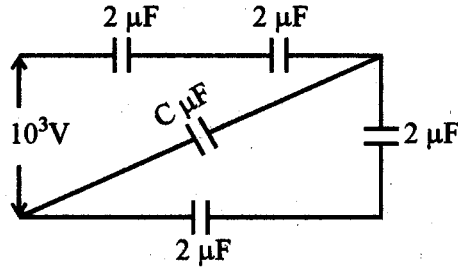

- (1) $\frac{1}{2}$ (2) 2
 (3) 2.5 (4) 3
29. See the diagram. Area of each plate is 2.0m^2 and $d = 2 \times 10^{-3}\text{m}$. A charge of $8.85 \times 10^{-8}\text{C}$ is given to Q. Then the potential of Q becomes

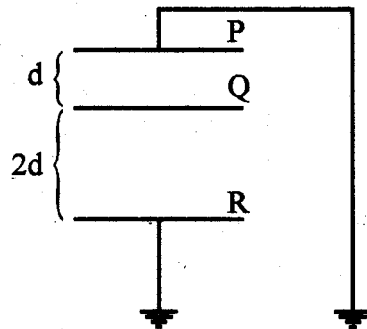

- (1) 13V (2) 10V
 (3) 6.67V (4) 8.825V

Space For Rough Work

30. Three conductors draw currents of 1 A, 2 A and 3 A respectively, when connected in turn across a battery. If they are connected in series and the combination is connected across the same battery, the current drawn will be

- (1) $\frac{2}{7}$ A (2) $\frac{3}{7}$ A
 (3) $\frac{4}{7}$ A (4) $\frac{5}{7}$ A

31. In the circuit, $R_1 = R_2$. The value of E and R_1 are _____ (E – EMF, R_1 – resistance)

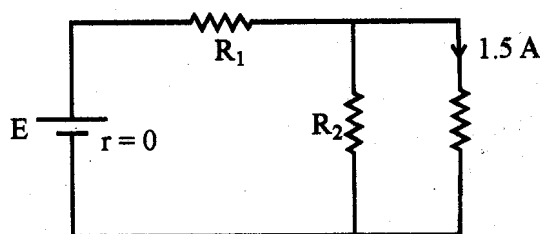

- (1) 180 V, 60 Ω (2) 120 V, 60 Ω
 (3) 180 V, 10 Ω (4) 120 V, 10 Ω

32. Masses of three wires of copper are in the ratio of 1 : 3 : 5 and their lengths are in the ratio of 5 : 3 : 1. The ratio of their electrical resistances is

- (1) 1 : 3 : 5 (2) 5 : 3 : 1
 (3) 1 : 15 : 125 (4) 125 : 15 : 1

33. For a transformer, the turns ratio is 3 and its efficiency is 0.75. The current flowing in the primary coil is 2 A and the voltage applied to it is 100 V. Then the voltage and the current flowing in the secondary coil are _____ respectively.

- (1) 150 V, 1.5 A (2) 300 V, 0.5 A
 (3) 300 V, 1.5 A (4) 150 V, 0.5 A

Space For Rough Work

34. A proton and helium nucleus are shot into a magnetic field at right angles to the field with same kinetic energy. Then the ratio of their radii is
 (1) 1 : 1 (2) 1 : 2
 (3) 2 : 1 (4) 1 : 4
35. Two identical circular coils A and B are kept on a horizontal tube side by side without touching each other. If the current in the coil A increases with time, in response, the coil B
 (1) is attracted by A (2) remains stationary
 (3) is repelled (4) rotates
36. In the diagram, I_1 , I_2 are the strength of the currents in the loop and straight conductors respectively. $OA = AB = R$. The net magnetic field at the centre O is zero. Then the ratio of the currents in the loop and the straight conductors is

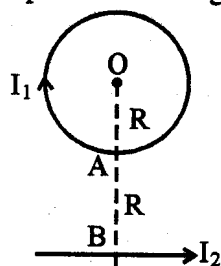

- (1) π (2) 2π
 (3) $\frac{1}{\pi}$ (4) $\frac{1}{2\pi}$
37. Two tangent galvanometers, which are identical except in their number of turns, are connected in parallel. The ratio of their resistances of the coils is 1 : 3. If the deflections in the two tangent galvanometers are 30° and 60° respectively, then the ratio of their number of turns is
 (1) 1 : 1 (2) 3 : 1
 (3) 1 : 2 (4) 1 : 6

Space For Rough Work

38. A charged particle with a velocity $2 \times 10^3 \text{ ms}^{-1}$ passes undeflected through electric field and magnetic fields in mutually perpendicular directions. The magnetic field is 1.5 T. The magnitude of electric field will be

- (1) $1.5 \times 10^3 \text{ NC}^{-1}$ (2) $2 \times 10^3 \text{ NC}^{-1}$
 (3) $3 \times 10^3 \text{ NC}^{-1}$ (4) $1.33 \times 10^3 \text{ NC}^{-1}$

39. In R-L-C series circuit, the potential differences across each element is 20 V. Now the value of the resistance alone is doubled, then P.D. across R, L and C respectively

- (1) 20 V, 10 V, 10 V (2) 20 V, 20 V, 20 V
 (3) 20 V, 40 V, 40 V (4) 10 V, 20 V, 20 V

40. A rectangular coil of 100 turns and size $0.1 \text{ m} \times 0.05 \text{ m}$ is placed perpendicular to a magnetic field of 0.1 T. If the field drops to 0.05 T in 0.05 second, the magnitude of the e.m.f. induced in the coil is

- (1) $\sqrt{2}$ (2) $\sqrt{3}$
 (3) $\sqrt{0.6}$ (4) $\sqrt{6}$

41. In the circuit diagram, heat produces in R, 2R and 1.5R are in the ratio of

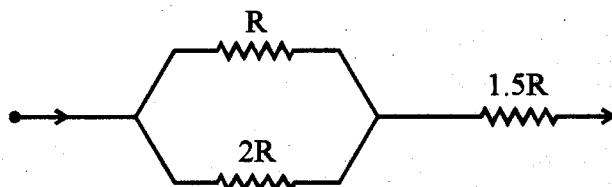

- (1) 4 : 2 : 3 (2) 8 : 4 : 27
 (3) 2 : 4 : 3 (4) 27 : 8 : 4

Space For Rough Work

42. A series combination of resistor (R), capacitor (C) is connected to an A.C. source of angular frequency ' ω '. Keeping the voltage same, if the frequency is changed to $\omega/3$, the current becomes half of the original current. Then the ratio of the capacitive reactance and resistance at the former frequency is
- (1) $\sqrt{0.6}$ (2) $\sqrt{3}$
(3) $\sqrt{2}$ (4) $\sqrt{6}$
43. Pick out the correct statement from the following :
- (1) Mercury vapour lamp produces line emission spectrum.
(2) Oil flame produces line emission spectrum.
(3) Band spectrum helps us to study molecular structure.
(4) Sunlight spectrum is an example for line absorption spectrum.
44. Light emitted during the deexcitation of electron from $n = 3$ to $n = 2$, when incident on a metal, photoelectrons are just emitted from that metal. In which of the following deexcitations photoelectric effect is not possible ?
- (1) From $n = 2$ to $n = 1$ (2) From $n = 3$ to $n = 1$
(3) From $n = 5$ to $n = 2$ (4) From $n = 4$ to $n = 3$
45. The additional energy that should be given to an electron to reduce its de-Broglie wavelength from 1 nm to 0.5 nm is
- (1) 2 times the initial kinetic energy
(2) 3 times the initial kinetic energy
(3) 0.5 times the initial kinetic energy
(4) 4 times the initial kinetic energy
46. The ionisation energy of an electron in the ground state of helium atom is 24.6 eV. The energy required to remove both the electron is
- (1) 51.8 eV (2) 79 eV
(3) 38.2 eV (4) 49.2 eV

Space For Rough Work

47. $\frac{\quad}{\quad} 3E$
 $\frac{\quad}{\quad} 5E/3$
 $\frac{\quad}{\quad} E$

The figure shows the energy level of certain atom. When the electron deexcites from $3E$ to E , an electromagnetic wave of wavelength λ is emitted. What is the wavelength of the electromagnetic wave emitted when the electron deexcites from $\frac{5E}{3}$ to E ?

- (1) 3λ (2) 2λ
 (3) 5λ (4) $\frac{3\lambda}{5}$
48. Maximum velocity of the photoelectron emitted by a metal is $1.8 \times 10^6 \text{ ms}^{-1}$. Take the value of specific charge of the electron is $1.8 \times 10^{11} \text{ C kg}^{-1}$. Then the stopping potential in volt is
- (1) 1 (2) 3
 (3) 9 (4) 6
49. λ_1 and λ_2 are used to illuminate the slits. β_1 and β_2 are the corresponding fringe widths. The wavelength λ_1 can produce photoelectric effect when incident on a metal. But the wavelength λ_2 cannot produce photoelectric effect. The correct relation between β_1 and β_2 is
- (1) $\beta_1 < \beta_2$ (2) $\beta_1 = \beta_2$
 (3) $\beta_1 > \beta_2$ (4) $\beta_1 \geq \beta_2$
50. Pick out the correct statement/s from the following :
- (a) Electron emission during β -decay is always accompanied by neutrino.
 (b) Nuclear force is charge independent.
 (c) Fusion is the chief source of stellar energy.
- (1) (a), (b) are correct. (2) (a), (c) are correct.
 (3) only (a) is correct. (4) (b), (c) are correct.

Space For Rough Work

51. A nucleus ${}_Z X^A$ emits an α -particle with velocity v . The recoil speed of the daughter nucleus is
- (1) $\frac{A-4}{4v}$ (2) $\frac{4v}{A-4}$
(3) v (4) $\frac{v}{4}$
52. A radioactive substance emits 100 beta particles in the first 2 seconds and 50 beta particles in the next 2 seconds. The mean life of the sample is
- (1) 4 seconds (2) 2 seconds
(3) $\frac{2}{0.693}$ seconds (4) 2×0.693 seconds
53. In which of the following statements, the obtained impure semiconductor is of p-type ?
- (1) Germanium is doped with bismuth (2) Silicon is doped with antimony
(3) Germanium is doped with gallium (4) Silicon is doped with phosphorus
54. The width of the depletion region in a P-N junction diode is
- (1) increased by reverse bias (2) increased by forward bias
(3) decreased by reverse bias (4) independent of the bias voltage
55. When the transistor is used as an amplifier
- (1) Emitter-base junction must be reverse biased, Collector-base junction must be forward biased.
(2) Emitter-base junction must be forward biased, Collector-base junction must be forward biased.
(3) Emitter-base junction must be reverse biased, Collector-base junction must be reverse biased.
(4) Emitter-base junction must be forward biased, Collector-base junction must be reverse biased.

Space For Rough Work

56. Which of the following is not made by quarks ?
- (1) Neutron (2) Positron
(3) Proton (4) π -meson
57. Which one of the following is NOT correct ?
- (1) In forward biased condition diode conducts.
(2) If the packing fraction is negative, the element is stable.
(3) Binding energy is the energy equivalent to mass defect.
(4) Radioactive element can undergo spontaneous fission.
58. The output of an OR gate is connected to both the inputs of a NAND gate. The combination will serve as
- (1) AND gate (2) NOT gate
(3) NAND gate (4) NOR gate
59. A and B are the two radioactive elements. The mixture of these elements show a total activity of 1200 disintegrations/minute. The half life of A is 1 day and that of B is 2 days. What will be the total activity after 4 days ? Given : The initial number of atoms in A and B are equal.
- (1) 200 dis/min (2) 250 dis/min
(3) 500 dis/min (4) 150 dis/min
60. The binding energy/nucleon of deuteron (${}_1\text{H}^2$) and the helium atom (${}_2\text{He}^4$) are 1.1 MeV and 7 MeV respectively. If the two deuteron atoms fuse to form a single helium atom, then the energy released is
- (1) 26.9 MeV (2) 25.8 MeV
(3) 23.6 MeV (4) 12.9 MeV

Space For Rough Work

SEAL

A-1