



ജില്ലാ വിദ്യാഭ്യാസ പരിശീലന ഇൻസ്റ്റിറ്റ്യൂട്ട് (ഡയറ്റ്)  
തൃശ്ശൂർ



# ഘോഷം 2021

എസ്. എസ്. എൽ. സി. വിദ്യാർത്ഥികൾക്കുള്ള പഠന സഹായി

**ഊർജ്ജതന്ത്രം**

District Institute of Education and Training  
Ramavarmapuram (P.O), Thrissur (Dist, Kerala, Pin : 680631  
Ph : 0487 2332070, Email : diettcr@gmail.com



**ജില്ലാ വിദ്യാഭ്യാസ പരിശീലന ഇൻസ്റ്റിറ്റ്യൂട്ട് (ഡയറ്റ്) തൃശൂർ.**

# **ഫോക്കസ് 2021.**

**എസ്.എസ്.എൽ.സി വിദ്യാർത്ഥികൾക്കുള്ള പഠന സഹായി.**

**Support Materials for SSLC March 2021.**

**അക്കാദമിക സഹായം.**

ജില്ലാ വിദ്യാഭ്യാസ പരിശീലന ഇൻസ്റ്റിറ്റ്യൂട്ട് കോഴിക്കോട്.

ജില്ലാ വിദ്യാഭ്യാസ പരിശീലന ഇൻസ്റ്റിറ്റ്യൂട്ട് ഇടുക്കി.

നിർമ്മാണ ചുമതല : സി എം ഡി ഇ വിഭാഗം ഡയറ്റ് തൃശൂർ.

പ്രസിദ്ധീകരിച്ചത് : 2021 ഫെബ്രുവരി.

പ്രിയ കുട്ടികളേ,

സ്കൂളിൽ പോയി കൂട്ടുകാരോടൊപ്പമിരുന്ന് അധ്യാപകരുടെ ക്ലാസ്സുകൾ കേൾക്കാനും പഠന പ്രവർത്തനങ്ങൾ നിർവ്വഹിക്കാനും കഴിയാത്ത ഒരു അധ്യയന വർഷമാണ് കടന്നു പോകുന്നത്. ലോകത്തെ മുഴുവൻ ഗ്രസിച്ച കോവിഡ് 19 രോഗബാധ നമ്മുടെ സാധാരണ അധ്യയന രീതികളെയൊക്കെ പുനഃസംവിധാനം ചെയ്യാൻ പ്രേരിപ്പിച്ചു. സംസ്ഥാനതലത്തിൽ ഫസ്റ്റ് ബെൽ ഓൺലൈൻ ക്ലാസ്സുകൾ മുഴുവൻ വിദ്യാർത്ഥികൾക്കും ലഭ്യമാക്കുകയും അധ്യാപകരുടെ പിന്തുണയോടെ പഠന പ്രക്രിയ പൂർത്തിയാക്കുകയുമാണ് നാം ചെയ്തത്. ഇനിയുള്ളത് കുട്ടികളുടെ സംശയ പരിഹാരണത്തിനും പരീക്ഷാ തയ്യാറെടുപ്പിനു മായുള്ള ദിനങ്ങളാണ്. ആത്മവിശ്വാസത്തോടെ എസ്.എസ്.എൽ.സി.പരീക്ഷ നേരിടുന്നതിനായി കുട്ടികളെ സുസജ്ജരാക്കേണ്ടതുണ്ട്. പരീക്ഷയ്ക്കായി കൂടുതൽ ഊന്നൽ നൽകി പഠിക്കേണ്ട പാഠ ഭാഗങ്ങൾ എസ്.സി.ആർ.ടി.നിർദ്ദേശിച്ചിട്ടുണ്ട്.

തൃശൂർ ഡയറ്റിന്റെ അക്കാദമിക നേതൃത്വത്തിൽ കോഴിക്കോട്, ഇടുക്കി ഡയറ്റുകളുടെ സഹകരണത്തോടെ എസ്.എസ്.എൽ.സി. ഫോക്കസ് ഏരിയകളെ ആധാരമാക്കിയുള്ള പ്രവർത്തനങ്ങൾ അടങ്ങിയ പഠന സഹായി തയ്യാറാക്കിയിരിക്കുകയാണ്. പരീക്ഷയുടെ തയ്യാറെടുപ്പുകൾക്കായി നേരിട്ട് അധ്യയനം ആരംഭിച്ച സാഹചര്യത്തിൽ പഠന പ്രവർത്തനങ്ങൾക്കായി അധ്യാപകരും വിദ്യാർത്ഥികളും "ഫോക്കസ് 2021" പഠന സഹായി ഫലപ്രദമായി ഉപയോഗിക്കുമെന്നും അത് അവരെ വിജയത്തിലേക്ക് നയിക്കുമെന്നും പ്രതീക്ഷിക്കുന്നു.

**ശ്രീമതി എൻ.ഗീത**

വിദ്യാഭ്യാസ ഉപഡയറക്ടർ  
തൃശൂർ

**ശ്രീ. ടി .അബ്ദുൾ നാസിർ**

പ്രിൻസിപ്പൽ,ഡയറ്റ്  
തൃശൂർ

# PHYSICS

## Effects of electric current

### Focus Area

Energy change in electrical devices

Heating effect of electric current.

Joule's Law, Electric Power– Problems

Electric heating appliances.

Safety fuse.

Arrangement of Resistors in Circuits– Series Connection and Parallel Connection – Mathematical problems

Lighting effect of electric current – Incandescent lamps

### Energy change in electrical devices

#### Activity 1

Names of some electrical devices are given in the table. Try to write down the energy changes taking place in each device.

Device	Energy change	Effects of electric current
Electric bulb	Electrical energy is converted to light energy	Lighting effect
Electric fan		
Electric cooker		
Electric stove		
Soldering iron		

### Heating effect of electric current

When electricity passes through a resistor, electrical energy is transformed to heat energy. The following equations can be used to find the amount of heat produced

$$H = Vit$$

$$H = I^2 Rt$$

$$H = V^2 t/R$$

### Joule's Law, Electric power

#### Activity 2

The heat generated in a current carrying conductor can be calculated using the formula given below.

$$H = I^2 Rt$$

Write the units and complete the table.

H Heat	Joule (J)
I Current	
R Resistance	
t Time	

Activity 3

A heating coil of resistance  $115 \Omega$  works in  $230 \text{ V}$

- a . Calculate the current in the circuit.
- b. write the equations to calculate the heat generated in a current carrying conductor.
- c. Calculate the heat generated in 5 minutes
- d. Write the equations to calculate the electric power.
- e. Calculate the power of this device.

**Electric heating appliances**

Activity 4

Electric heating appliances have a main part in which electrical energy changes into heat energy.

- a) Name that part  
.....
- b) Which material is used to make this part?  
.....
- c) What are the peculiarities of this part?  
.....

**Safety fuse**

Activity 5

Safety fuse is a device that works on the heating effect of electric current.



- a) Which material is used as fuse wire in a safety fuse?
- b) What is the peculiarity of a fuse wire?

**Arrangement of Resistors in Circuits Series Connection ,Parallel Connection.**

Activity 6

Observe the circuits given below. Two resistors connected in two different ways are given here. Mark the path of current from positive to negative,

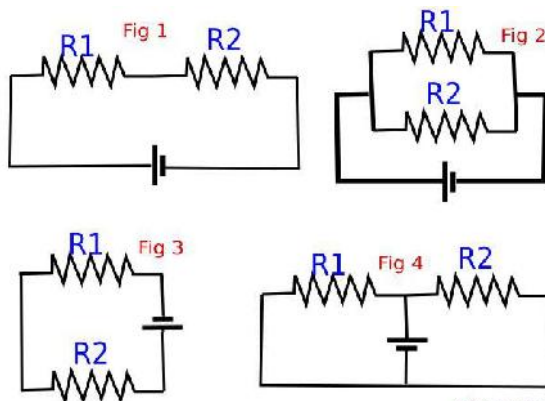

compare your answers with given figure below. In two figures we can see there are more than one path for current to complete the circuit

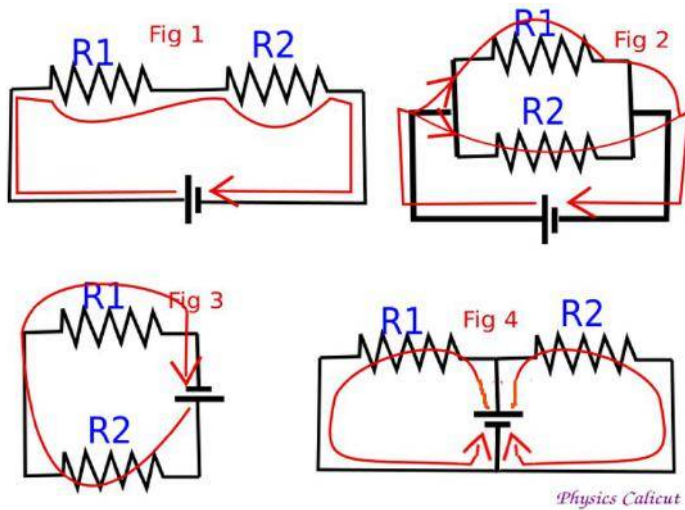

Tabulate above figures ,as parrallel or series connections

Parallel connections	Series connections

#### Merits of Parallel connections

- \*The potential difference in each resistors is the same.
- \* Current through each resistors are different.
- \* The effective resistance decreases.
- \*We can control each device using separate switches .

If res s tors of same value are connected n parrallel,then  $R = \frac{r}{n}$ , where 'n' s the number of res tors ,and 'r' s the res stance of one res stor.

#### Activity 7

Two resistors of  $2\ \Omega, 3\ \Omega, 6\ V$  battery and connecting wires are given

- a. Depict a figure of series connection using these components.
- b. Calculate the effective resistance of series connection.
- c. Calculate the current in the circuit.
- d. Do the potential defference across each resistor is equal in series connection.
- e. Depict a figure of Parallel connections.
- f. Calculate the effective resistance, if resistors conneccted in parallel.
- g. Calculate the current in the circuit.in parallel connection.
- h. Calculate the current through each resistor when connected in parallel.

Lighting effect of electric current Incandescent lamps .

Activity 8

Incandescent lamps make use of Lighting effect of electric current .Name the parts of a filament lamp?

Activity 9

- a)Which is the material used as filament in incandescent lamps?
- b)Why the bulb is filled with inert gas?
- c)What properties of tungsten make it suitable for being used as a filament?
- d)Why the the bulb is evacuated.?
- e)The efficiency of incandescent lamp is less.Why?

\*\*\*\*\*

Answer key

Activity 1

Device	Energy change	Effect of electric current
Electric bulb	Electrical energy is converted to light energy	Lighting effect
Electric Fan	Electrical energy is converted to mechanical energy	mechanical effect
Electric cooker	Electrical energy is converted to heat energy	Heating effect
Electric stove	Electrical energy is converted to heat energy	Heating effect
Soldering iron	Electrical energy is converted to heat energy	Heating effect

Activity 2

H Heat	Joule (J)
I Current	Ampere (A)
R Resistance	Ohm ( $\Omega$ )
t Time	Second (s)

Activity 3

- a)  $I = V/R = 230/115 = 2A$
- b)  $H = Vit$  ,  $H = I^2 Rt$  ,  $H = V^2 t/R$
- c)  $H = Vit = 230 \times 2 \times 300 = 230 \times 600 = 138000J$
- d)  $P = VI$  .  $P = I^2 R$  .  $P = V^2/R$
- e.)  $P = VI = 230 \times 2 = 460W$

Activity 4

- a) Heating coil
- b) Nichrome
- c) High resistivity, High melting point

Activity 5

- a)Alloy of tin and lead.
- b) Low melting point



Activity 6

Series	Parrallel
Fig 1 Fig 3	Fig 2 Fig 4

Activity 7

a.)

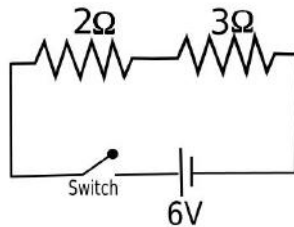

b.) Effective resistance when connected in series ,R R1+R2 2+3 5 Ω

c.) I V/R 6/5 1.2A

d.)No.The potential difference between the ends of each resistor will be different.

e.)

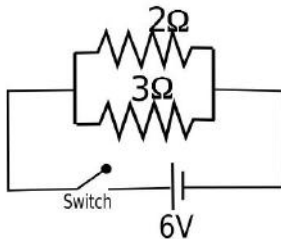

f.)R (R1 x R2 )/(R1 + R2 ) (2 x 3)/(2+3) 6/5 1.2 Ω

g.)Current, I V/R 6/1.2 5A

h.) Current through 2 Ω resistor V/R 6/2 3A  
Current through 3 Ω resistor V/R 6/ 2A

Activity 8

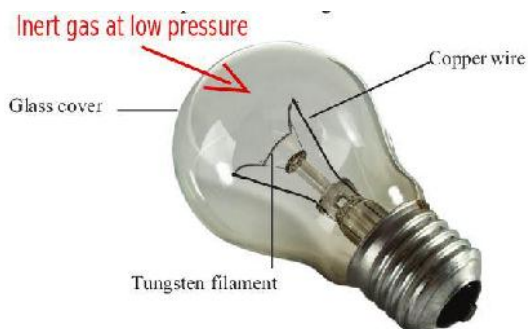

Activity 9

a) Tungsten

b) To reduce the vaporisation of filament.

c) High resistivity ,high melting point ,high ductility ,ability to emit white light in the white hot condition

d) To avoid oxidation of tungsten

e)A major part of the electrical energy supplied to an incandescent lamp is lost as heat. Hence the efficiency of these devices is less.

# Magnetic Effect of Electric current

## Activity 1

Observe the figure. Current is passed through a conductor placed above and close to a magnetic needle.(from A to B).What is the direction in which the North Pole(N) of the magnetic needle deflects?

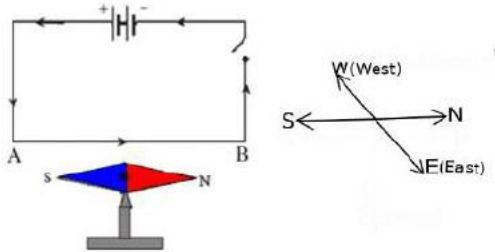

- a)East b)North c)West d)South.

(The figure is taken from the text book.You can use the figure below also for more clarity.)

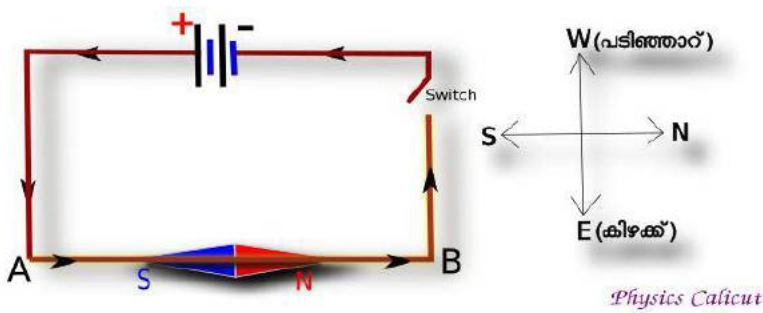

What are the concepts that we have to consider while answering this question?

1. There will be a magnetic field around a current carrying conductor

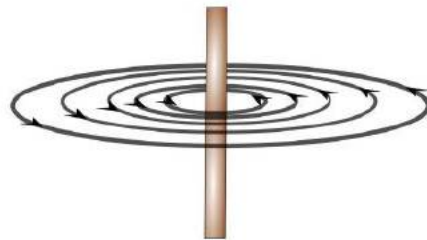

2. We can use Right hand thumb rule to find the direction of magnetic field.

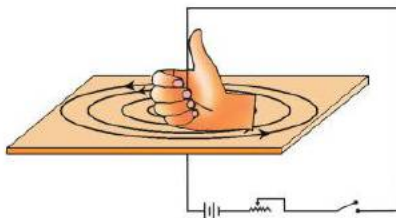

3. The deflection of magnetic needle is due to the interaction between the magnetic field caused by the current carrying conductor and its own magnetic field.

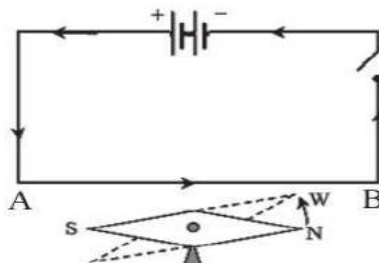

So the north pole of the needle is deflected towards west.

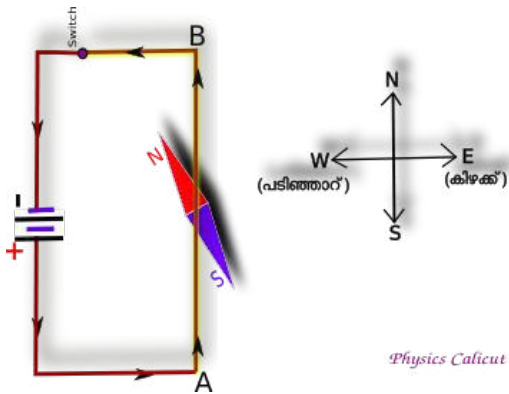

Activity 2

1) The magnetic field produced by a current carrying conductor is depicted in the figure. What will be the direction of electric current?

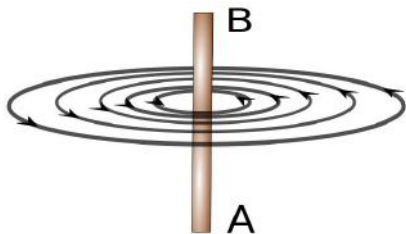

2) Write the law that can be used to find the direction of magnetic field produced by a current carrying straight conductor.

Activity 3

The magnetic field produced by a solenoid is shown in the figure. What will be the polarities of the battery at points A and B ?

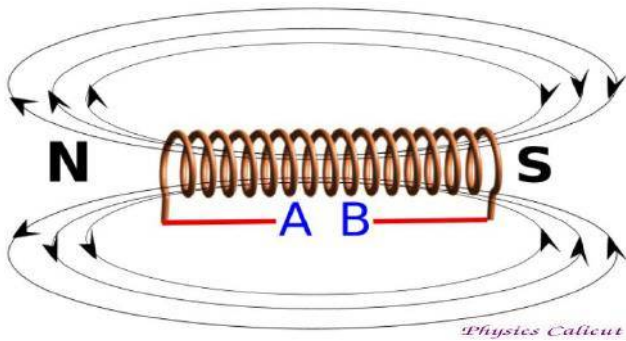

What are the concepts that we have to consider while answering this question?

1) Magnetic field produced by a solenoid and magnetic field of a bar magnet are similar.

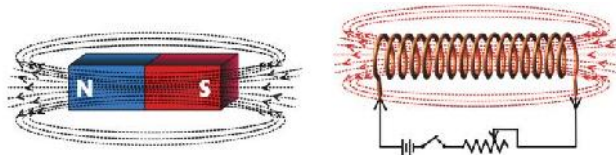

2) If North pole is induced at one end of a solenoid the direction of current will be in anticlockwise direction at that end.

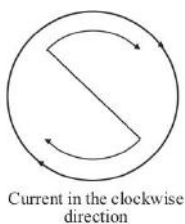

3) For current to be anticlockwise at the end of the solenoid where north pole is formed ,the terminal "A" must be negative.

4) If South pole is induced at one end of a solenoid the direction of current will be in clockwise direction at that end.

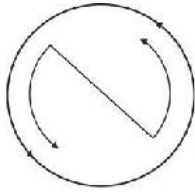

Current in the anti clockwise direction

5) For current to be clockwise at the end of the solenoid where south pole is formed ,the terminal "B" must be positive.

#### Activity 4

Write any two factors that affect the strength of the magnetic field of a solenoid carrying current.

#### Activity 5

Observe the figure . **When the circuit is switched on ,the conductor AB moves outward.**

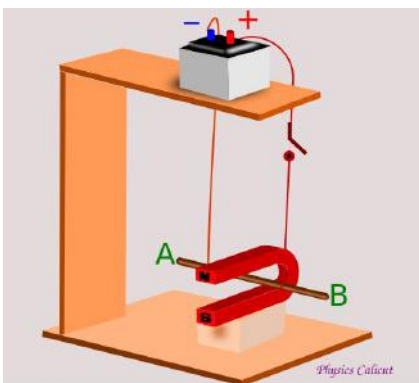

a) Write the principle behind this movement of the conductor .

b) Write the name of a device that make use of this principle.

#### Activity 6

Note the parts of an electric motor shown in the figure

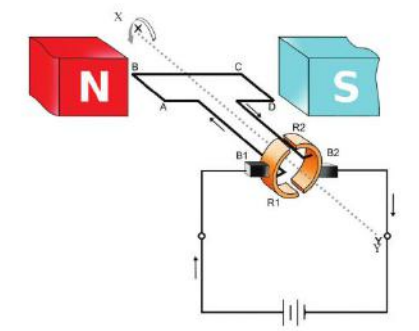

Write the name of the parts represented by NS, ABCD, B1,B2, R1and R2 .

#### Activity 7

In the split ring commutator of a DC motor, semi circular rings are used.

What is the need for this?

#### Activity 8

What is the energy transformation taking place in an electric motor?

#### Activity 9

Observe the picture showing the structure of a loud speaker.

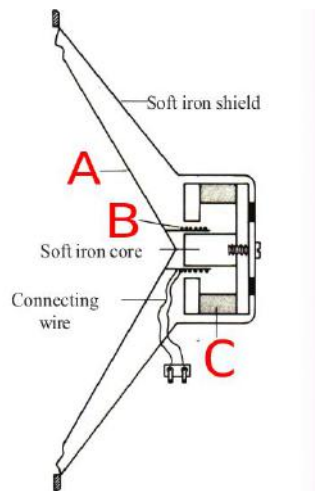

Name the parts shown as A,B and C .

Activity 10

What is the energy transformation taking place in a moving coil loud speaker.

### Answer Key

Activity 1

Ans) c)West

Activity 2

Ans) From A to B.

2) Right Hand Thumb Rule of James Clark Maxwell.

*Imagine you are holding a current carrying conductor with the right hand in such a way, that the thumb points in the direction of the current. The direction in which the other fingers encircle the conductor gives the direction of the magnetic field.*

Activity 3

Ans) A Negative, B Positive

Activity 4

Ans) Intensity of electric current , number of turns in the coil ,distance between the turns.

Activity 5

Ans) a)Motor principle. b)Electric motor, moving coil loud speaker.

Activity 6

Ans) NS Magnetic poles ,ABCD Armature, B1,B2 Graphite brushes ,R1,R2 Split rings.

Activity 7

Ans) If the rotation of the armature is to be sustained the direction of current through the armature should continuously keep on changing. The split rings help to change the direction of current through the coil after every half rotation.

Activity 8

Ans) Electrical energy is converted to mechanical energy.

Activity 9

Ans) A Diaphragm , B Voice coil , C Field magnet.

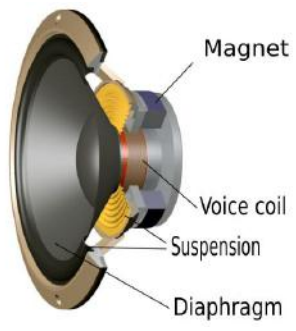

Activity 10

Ans) Electrical energy is converted to mechanical energy.

\*\*\*\*\*

# Electromagnetic induction

## Focus area

Electromagnetic induction, factors influencing induced emf, power from AC generator, DC generator and cell, - features, graphic illustration .AC generator DC generator - structure, function, self induction, mutual induction, transformers - structure, function, moving coil microphone, high voltage power transmission, electric shock - precautions, first aid.

### Activity 1.

Both ends of a solenoid are connected to a galvanometer. A bar magnet is moving in and out of this solenoid

a). Observe the figure. Figure conveys some information. What will you observe in the galvanometer ?

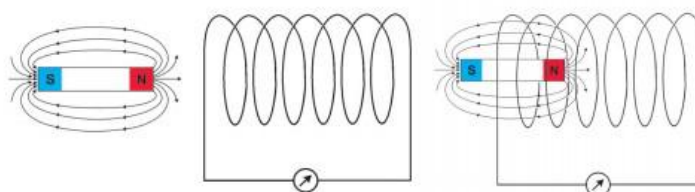

b). What is the reason for this phenomenon? Explain.

c). What change can be observed by increasing the speed of motion?

d). Suggest the methods increase the emf generated?

### Activity 2.

Observe the figure ,

a. Name this device?

b. Draw the diagram and label the parts.

c. Draw the graph of the emf generated by this device.

d. What is the name of power generated by this device ?

e. The number of cycles per second is termed as .....

f. What is the frequency of A C produced in India?

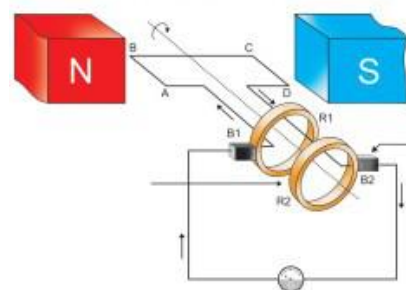

### Activity. 3

Observe the figure,

1. Name this device.

2. What is the energy change taking place in it?

3. Draw a diagram showing the position of armature after half rotation (if rotated 180 degrees) from the current position and label its parts.

4. What is its working principle?

5. Draw the graph of emf generated from this device.

6. What are the changes to be made to get AC from this device? (2 possibilities)

7. How can we change this device into a motor?

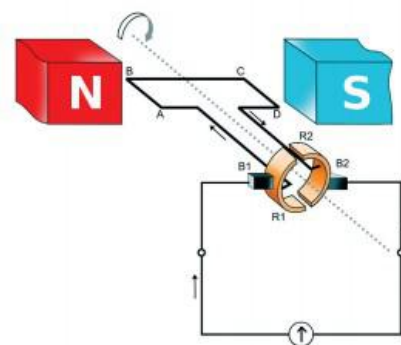

#### Activity 4.

Cell.

- Name the current flowing only in one direction?
- Draw a graph of the emf produced by the battery
- In which category does the current from a battery belong? (AC / DC)

#### Activity 5

Observe the figure,

- Turn on the switch in the given circuit. After a while, turn off it.

- What will be the observation?
- Write the reason.
- Name the coil in the input circuit ?
- Name the coil in the output circuit ?
- Which principle can be explained by this experiment ?
- Explain that principle.

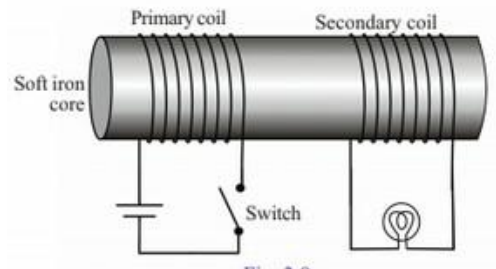

- What will be your observation, if you replace the cell by an AC source ?

#### Activity 6.

Observe the figure,

- Which device is given in the figure ?
- Write the working principle?
- What is the reason for using thick coil in its primary?
- Number of turns in the secondary is more .why ?
- In which stage, the step up transformer is used in power transmission ?
- What should be the change in the structure to reduce the output voltage?
- Draw its figure

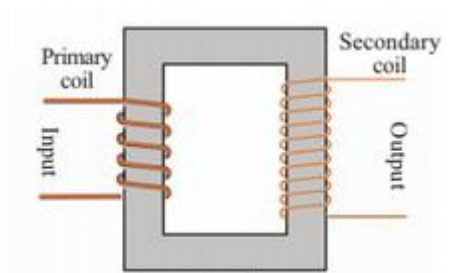

#### Activity 7

The power of the bulbs, the number of turns and the input voltage in the following circuits are the same. A piece of soft iron is placed inside the third solenoid .

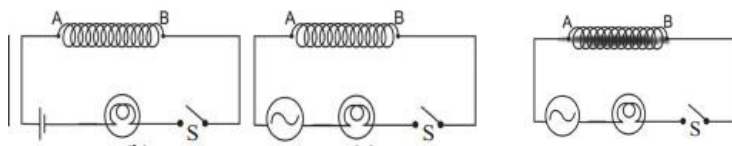

fig 1

fig 2

fig 3

- Which bulb will glow with more intensity when switched on? Give reason?
- Which bulb will glow with low intensity when switched on? Give reason?
- What is the phenomenon in connection with this experiment? Explain?



### Activity 8,

Observe the figure,

1. Name the device i given?
2. What is the energy change in it ?
3. Which is the working principle of this device ?
4. Label the main parts.
5. How does it work?
6. Compare this device with moving coil loudspeaker

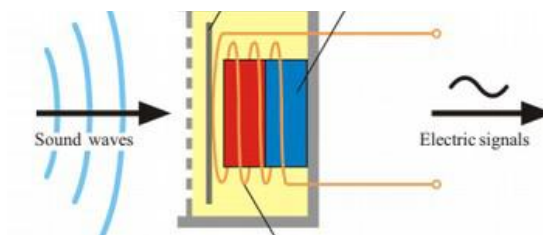

### Activity 9,

Power transmission

1. In which voltage electricity is produced in the power stations of India ?
2. What is the reason for converting this power to high voltage? Explain.
3. Which device helps for this?

### Activity 10,

Electric shock

1. What are the precautions to be taken to avoid electric shock?
2. What are the first aid to be given to a person who has received an electric shock?

## Electromagnetic induction

key

Activity 1

- a. The needle will move
- b. Electromagnetic induction + definition TB page 48
- c. The amount of electricity will increase
- d. Increase the number of turns, increase the magnetic strength, increase the speed of motion

Activity 2

- a. AC generator
- b. TB Image. 3.5b
- c. TB Image. 3.6 / table 3.5
- d. Alternating current (AC)
- e. Frequency
- f. 50 Hz

Activity 3

1. DC Generator
2. Mechanical energy becomes electrical energy
3. TB image 3.7.b
4. Electromagnetic induction
5. TB table 3.5
6. Replace the slip ring instead of split ring, / rotate the magnet, keeping armature stationary
7. Replace the galvanometer with the cell / TB image.2.12

Activity 4.

- a. Direct current (DC)
- b. TB table 3.5
- c. D.C.

Activity 5

- a. The bulb glows only when the switch is turned on and off
- b. The current induced in the secondary due to the difference in the current in the primary / Mutual induction
- c Primary coil
- d. Secondary coil
- e. Mutual induction
- f TB p 56 .
- g The bulb glows continuously

Activity 6

- 1.Step up transformer
- 2 Mutual induction
- 3. There is more current. To reduce heat by reducing resistance .
- 4. To increase the voltage
- 5. At the power station
- 6. The number of secondary coil should be reduced compared to the primary
- 7. TB Image3.10 b

Activity 7

- a. Figure 1.d c has no self-induction
- b. Figure 3. a c has self induction. The iron core increases the magnetism and thus the back emf increase
- c. Self Induction. Definition TB page 59

Activity 8

- 1 moving coil microphone
- 2 Mechanical energy to electrical energy
- 3. Electromagnetic induction
- 4. TB Image 60
- 5. TB Page.61
- 6. Similarities: There is a permanent magnet, a voice coil and a diaphragm

Differences:

	Moving coil microphone	Moving coil loud speaker
Energy change	Mechanical energy to electrical energy	Electrical energy to mechanical energy
principle	Electromagnetic induction	Motor principle

Activity 9

- 1. 11 k V (11000 v)
- 2. The current should be reduced to reduce the energy loss in the form of heat .Then the voltage should be increased to prevent power loss.
- 3. Step up transformer

Activity 10

- 1 TB Page: 69
- 2 TB Page:70

# 4

# Reflection of Light

## Focus Area

**Reflection of light.**

**Laws of reflection.**

**Features of image formed by Convex and Concave mirrors**

**Mirror equations**

**New Cartesian Sign Convention**

**Magnification**

---

### Activity I

Light falling on the surface of an object comes back to the same medium . This is reflection of light. This occurs in accordance with the laws of reflection of light.

**Observe the following figure which represents reflection of light and answer the questions.**

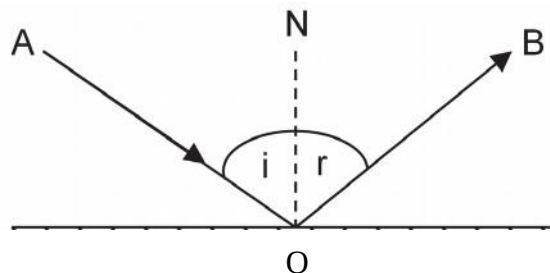

- Which is the incident ray?
- Which is the reflected ray?
- If 'i' is the angle of incidence , 'r' is the angle of reflection and 'N' is the normal to the mirror at the point of incidence, is there any relation between the angle of incidence and the angle of reflection?
- Are the incident ray, reflected ray and normal to the mirror at the point of incidence in the different planes?
- On the basis of the answers write down the laws of reflection.

### Activity II

**Which of the following represents regular reflection**

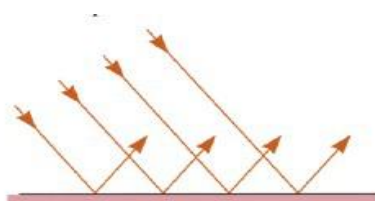

fig(a)

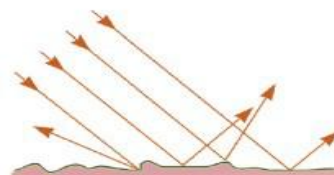

fig(b)

**Activity III**

The following figures represent plain mirror and spherical mirrors (convex and concave mirrors) Identify the figure which represents Concave mirror and convex mirror.



**Activity IV**

While using a concave mirror, the position and nature of image changes in accordance with the change in the position of the object,

Analyse the following figures and complete the table.

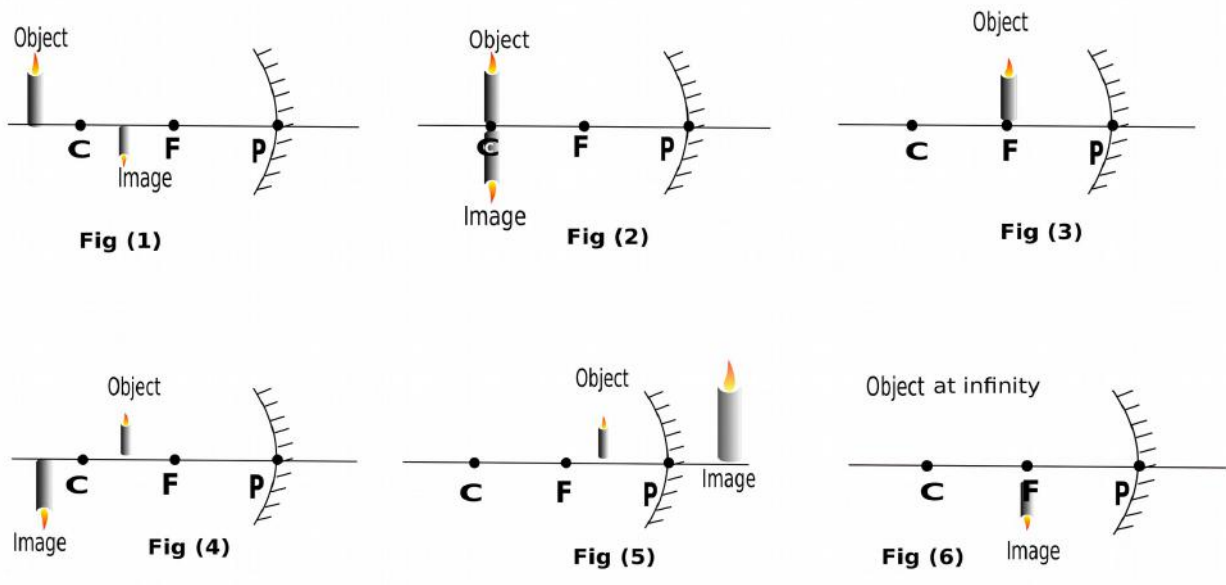

*C – Centre of curvature , F – Principle Focus, P – Pole*

Concave mirror		
Position of the object	Position of the image	Nature of the image
Beyond C	Between C and F	Diminished, Inverted, Real
At C		
At F		
Between C and F		
Between F and P		
At infinity		

### Activity V

The position of the object and the position of the image are related and the relation can be explained using an equation called mirror equation.

$$\frac{1}{f} = \frac{1}{u} + \frac{1}{v}$$

Where

f = The focal length of the mirror ( Distance of the principle focus from the pole)

u = The distance of the object from the pole

v = The distance of the image from the pole

For the calculation of f , u , or v certain sign convention has been formulated called **New Cartesian Sign Convention**

*Analyse the following figure and answer the questions.*

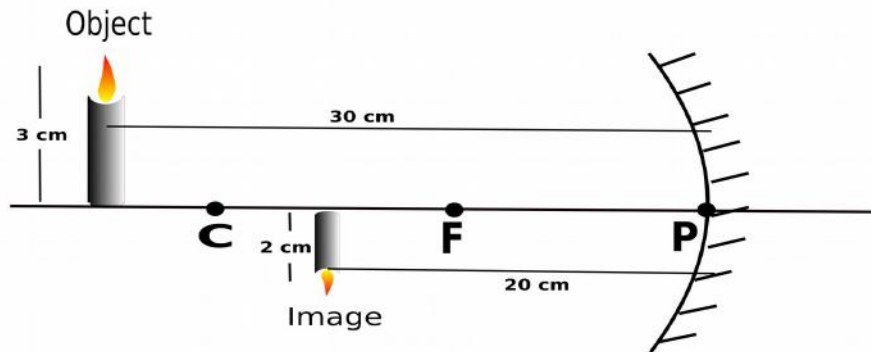

- Distance to the object from the mirror (u) = .....
- Distance to the image from the mirror (v) = .....
- Height of object = .....
- Height of image = .....
- Find the focal length (f)

### Activity VI

Magnification is the ratio of size of the image( $h_i$ ) to the size of the object( $h_o$ ) . Magnification 'm' can be calculated by using the following equations

$$m = \frac{h_i}{h_o} = \frac{-v}{u}$$

***When an object of height 6 cm is placed in front of a concave mirror at a distance 10 cm away from it , an image is obtained 16 cm away, on the same side. Find out the height of image and magnification.***

### **Activity VII**

***Identify the correct statements.***

- a) When magnification is 1, the size of the image and the size of the object are equal.
- b) When magnification is more than 1, the size of the image is greater than the size of the object.
- c) When magnification is less than 1, the size of the image is smaller than the size of the object.
- d) When the magnification is positive, image is real and inverted.
- e) When the magnification is negative, image is virtual and erect.

### **Activity VIII**

***Which type of mirror is used as rear view mirrors in vehicles ?***

( Convex mirror / Concave mirror )

### **Activity IX**

***Which of the following statements are correct related to convex mirror ?***

- a) Image is formed between the centre of curvature and the principal focus.
- b) Image is formed between the pole and the principal focus.
- c) The image is diminished, virtual and erect
- d) The image is enlarged, real and erect

### **Activity X**

***Which mirror always gives an erect and diminished image?***

## Answer Key

### Activity I

- a) AO
- b) OB
- c)  $i = r$
- d) No. All are in the same plane
- e) When light is reflected from a smooth surface, the angle of incidence and angle of reflection are equal. The incident ray, reflected ray and normal to the surface are in the same plane.

### Activity II

Fig(a)

### Activity III

B-Concave , C and D - Convex

### Activity IV

At C – Same size, Inverted, Real  
No image ( or at infinity)  
Beyond C – Enlarged, Inverted, Real  
On the other side – Enlarged, Erect, Virtual  
At F – Diminished, Inverted, Real

### Activity V

- a) -30 cm, b) -20 cm, c) 3 cm, d) 2 cm
- e)

$$f = \frac{uv}{u+v} = \frac{-30 \times -20}{-30 + -20} = \frac{600}{-50} = -12 \text{ cm}$$

### Activity VI

$$h_o = 6 \text{ cm} , \quad u = -10 \text{ cm} , \quad v = -16 \text{ cm} , \quad m = \frac{-v}{u} = -(-16) / -10 = -1.6 .$$

$$m = h_i / h_o . \text{ Therefore, } h_i = m \times h_o = -1.6 \times 6 = -9.6 \text{ cm}$$

### Activity VII

a , b ,and c

### Activity VIII

Convex

### Activity IX

b and c

### Activity X

Convex mirror

## 5 REFRACTION OF LIGHT

### Focus Area

- ★ **Refraction**
- ★ **Speed of light and optical density**
- ★ **Total Internal Reflection**
- ★ **Lens-Important terms**
- ★ **Formation of image using a lens**
- ★ **Ray diagram of formation of images by lenses**
- ★ **Characteristics of the image**

1.

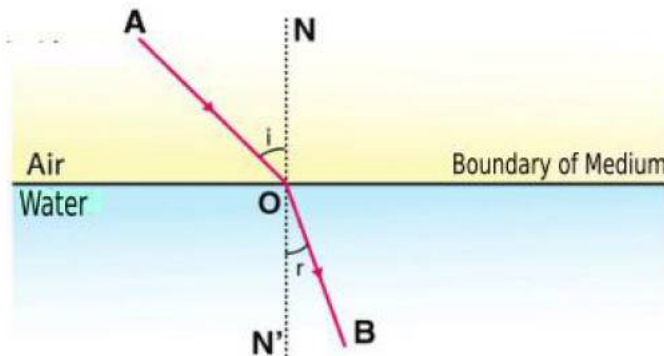

- a. Which are the media that light passes
- b. Which medium is given with greater optical density
- c. What happens to the path of the light
- d. Where does the deviation of the light take place
- e. Name this phenomenon
- f. What is the main reason of it

2. Some light conducting medium are given in the bracket

[ Vacuum, Diamond, Water, Glass ]

- a. Which is of greater optical density
- b. Arrange the media in the decreasing order of their speed of light
- c. What is the relation between optical density and speed of light

3. Ray diagrams of a light ray passing through different media are depicted. Observe the figure and complete the given table

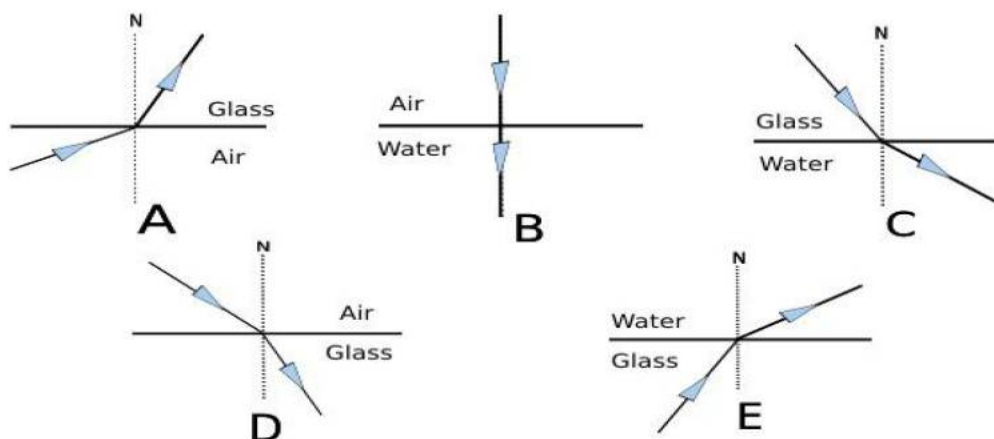



Situation	Figure
a) The refracted ray deviates away from the normal	
b) The refracted ray deviates towards the normal	
c) No deviation takes place in the light ray	

4. Observe the diagram and answer the following questions

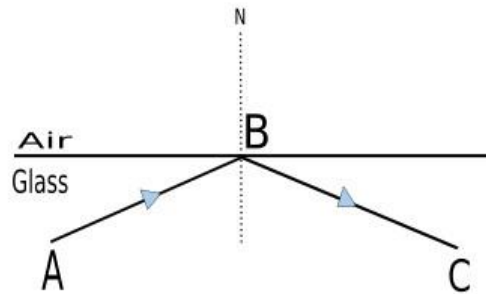

- What are the conditions for reflection of light ray AB in the direction BC
- What is the phenomenon called
- Write the practical applications of this phenomena in our daily life
- If angle of incidence is  $42^\circ$  What is the angle of refraction at that time.  
[ Critical angle of water =  $48.6^\circ$ , glass =  $42^\circ$  ]
- If angle of incidence is  $35^\circ$  at B .What are the phenomenon take place here

5. Write the name of the points depicted in the below diagram

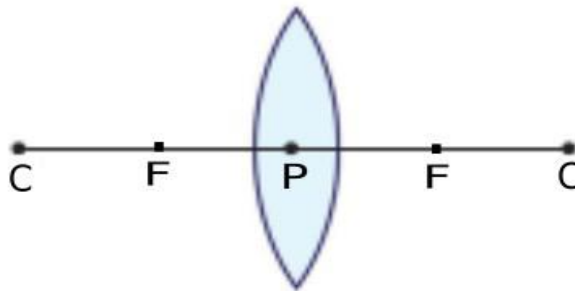

6. Complete the given ray diagram and mark the principal focus of the convex lens

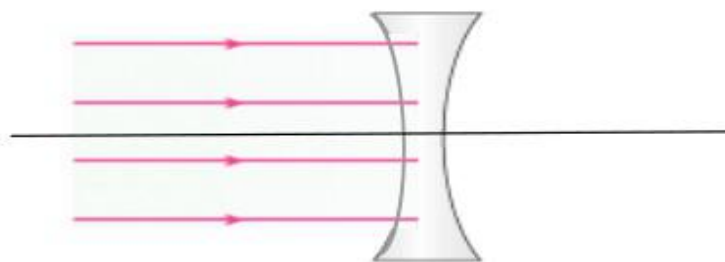

7. OB is an object placed in front of a convex lens

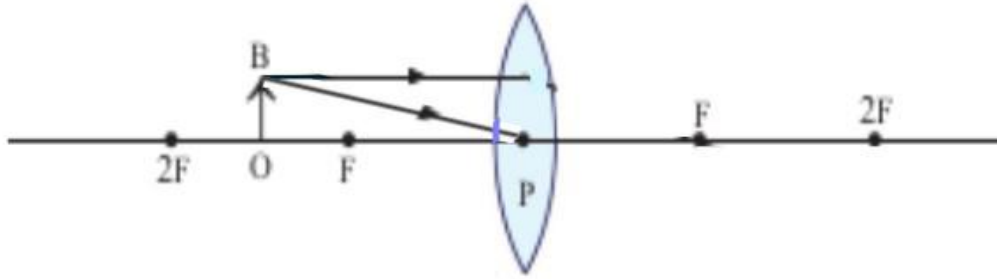

- a. Draw the ray diagram showing the image formation
- b. What is the position of image
- c. Write two features of image
- d. Where should the object be placed for getting an image having the same size of the object
- e. For getting virtual image where should the object be placed

### ANSWER KEY

1. a) Air, Water  
b) Water  
c) Path of light deviated  
d) Boundary of mediums  
e) Difference in densities of medium through which light ray passes
2. a) Diamond  
b) Vacuum, Water, Glass, Diamond  
c) Speed of light decreases with increasing optical density of the medium
3. a) C, E, b) A, D c) B
4. i) Light ray should obliquely incident from denser medium to rarer medium  
ii) Angle of incidence should be greater than critical angle  
iii) In Medical field – Endoscope, In Telecommunication - Optical fibre cable  
iv)  $90^\circ$   
v) Reflection, Refraction
5. P - Optic Centre, F - Principal focus, C - Centre of curvature
- 6.

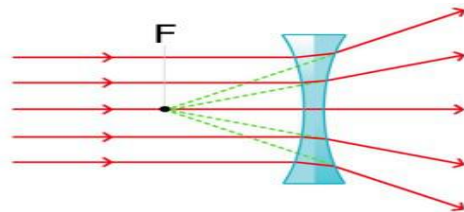

7. a.

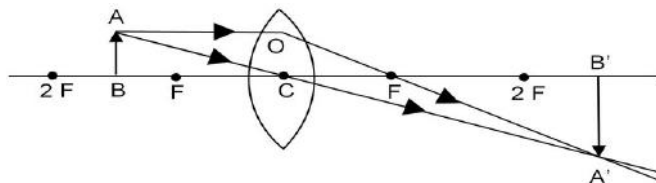

- b. Beyond 2F
- c. Real, Inverted, Larger than object
- d. Position of object - At 2F  
Position of image - At 2F
- e. Between focus (F) and Pole (P)

# vision and the world of colours

## FOCUS AREA

Dispersion of light, Recombination of colours, Rainbow, Persistence of vision, Scattering of light, Scattering and wavelength

### Dispersion of light

- ❖ Any light that is composed of more than one colour is a composite light.
- ❖ Dispersion is the phenomenon of splitting up of a composite light into its constituent colours.
- ❖ The regular array of colours formed by dispersion is the visible spectrum.
- ❖ The wavelength is different for different colors. Less violet and more red
- ❖ As the wavelength decreases, the deviation due to refraction increases

1 Sunlight splits into components as a result of passing through a prism

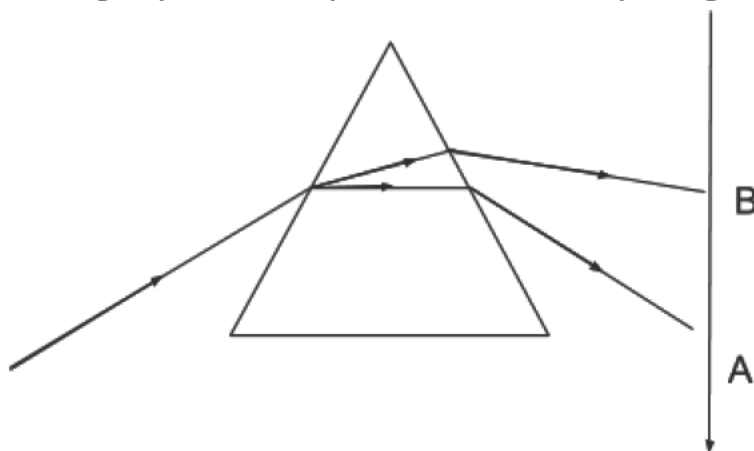

- Which phenomenon is mentioned in the given figure?
- A light is composed of more than one colour is
- which are the colours represent A to B
- what may be the reason behind difference in deviation of colors

### Rainbow

- ❖ Sunlight, when it passes through water droplets, undergoes

refraction and internal reflection.

- ❖ The light ray emerging from the water droplets which make the same angle with the line of vision have the same colour. These droplets appear in the form of an arc of a particular colour.
- ❖ Thus there is red colour at the upper edge and violet colour at the lower edge.
- ❖ All the other colours are seen in between, depending on their wavelengths.
- ❖ When seen from an aeroplane, the rainbow is seen as a circle.

2 Diagram of white light falling on water drop is given below

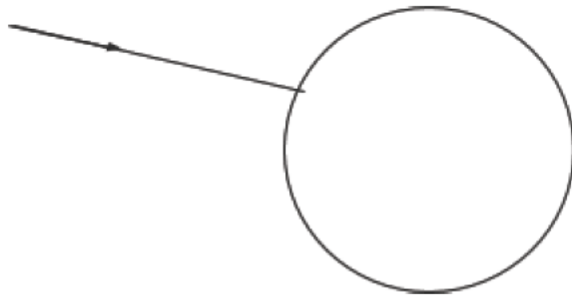

- a) complete the diagram
- b) How rainbow occur
- c) which are the colours that can be observed in the outer and inner edge of the rainbow.
- d) what is the shape of rainbow when we seen from an aeroplane

### Recombination of colours

- ❖ When the constituent colors of white light are added, white light is obtained again.

### Persistence of vision

- ❖ When an object is viewed by a person, its image remains in the retina of the eye for a time interval of 0.0625s (1/16 s) after seeing it
- ❖ The Newton's colour disc appeared white while rotating due to persistence of vision.,
- ❖ A torch rotated rapidly appears as an illuminated circle-eg:

3 consider two prism places as in fig.

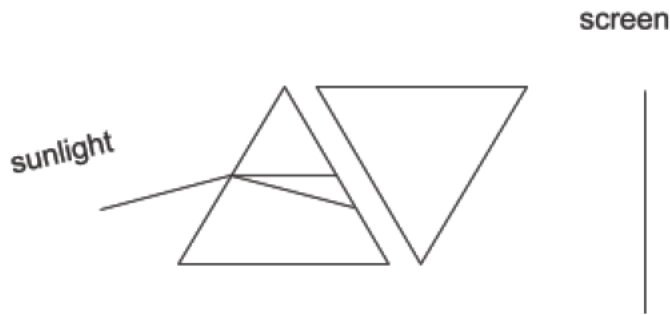

- What is the color (colors) that fall on the screen?
- Why does Newton's colour disc become white when rotating fast.?explain
- Find out examples of persistence of vision

### **Scattering of light, Scattering and wavelength**

- ❖ Scattering is the change in direction brought out by the irregular and partial reflection of light when it hits the particles of the medium.
- ❖ As the wavelength decreases, the scattering increases
- ❖ Colours like violet, indigo and blue have the smallest wavelengths in sunlight. They undergo maximum scattering while interacting with atmosphere particles.
- ❖ Red has comparatively greater wavelength and it can overcome small obstacles and hence scattering is low. As a result they travel greater distances.

4 Even though light travels in straight line we get light in our classrooms

- What is scattering of light
- Which colour of light undergoes maximum scattering ? Why
- During sunrise and sunset the sun becomes red why?
- Why red colour has been given to tail lamp / signal lights
- If atmospheric pollution increases near factories , the sky becomes dark .why?

## ANSWER KEY

- a) Scattering
- b) composite light.
- c) VIBGYOR
- d) The change in direction due to refraction depends on the wavelength. The violet with the shortest wavelength has greater variation.

2

- a) Tb Figure 6.10
- b) Sunlight hits the water droplets in the atmosphere and undergoes refraction and total internal reflection. As a result, sunlight is converted into components. This is how the rainbow is formed
- c) Violet on the inner edge and red on the outer edge
- d) Circular.

3

- a white light
- b Persistence of vision

TB Page 141

c Raindrops look like a glass rod, the film is made with continuous stills.

- 4
- a) Scattering is the change in direction brought out by the irregular and partial reflection of light when it hits the particles of the medium.
  - b) Violet - Due to its short wavelength, even small obstacles cannot be overcome.
  - c) At sunrise, sunlight has to travel farther through the atmosphere, so short-wavelength colors are lost due to scattering.
  - d) Reds with longer wavelengths have less scattering, so they travel longer distances.
  - e) As the air pollution increases, the number and size of the particles in the atmosphere increase, causing scattering and loss of all colors.

## 7 ENERGY MANAGEMENT

### FOCUS AREA

Fossil fuels-coal  
CNG,LNG,LPG.LPG and safety  
Green energy,Brown energy  
Energy crisis-reasons and solutions

#### 1.Fossil fuels are used in industries and vehicles

- How fossil fuels are formed ?
- Which is the most abundant fossil fuel on the earth ?
- Based on the carbon content coal is classified into four groups. Which are them ?
- Which are the substances obtained by the distillation of coal in the absence of air.

#### 2. You may be using cooking gas in your houses.

- Which is the fuel using as cooking gas ?
- LPG is a colourless odourless gas but it produces an odour when there is leakage of LPG.Give reason.
- It is marked D22 on a LPG cylinder.What do you understand from this?
- BLEVE is an activity connected with leakage of LPG.What does it mean ?
- Write two precautions to be taken to avoid accidents due to leakage of LPG
- What are the disaster management measures to be taken in case of LPG leakage.

3.Find the relationship with the first pair and complete the second pair

- Kerosene : Petroleum  
Ammonia : .....
- LPG : Butane  
CNG : .....

#### 4.Prime Minister dedicated Cochin-Mangalore natural gas pipeline to the Nation-News

- Which fuel is mentioned in the News ?select from the bracket  
(CNG,LNG,LPG)
- What is the significance of this fuel compared to others.

#### 5.Wind Energy is considered as Green Energy.

- What is meant by Green Energy?
  - What must be done to ensure utilization of Green Energy while constructing a house.
  - Nuclear Energy is considered as Brown Energy. Justify
  - Classify energy from the following sources as Brown Energy and Green Energy  
Atomic Reactor, Solar cells,Hydro electric Power, Diesel Engines
- 6.a)What is meant by Energy crisis.  
b)Suggest four ways to reduce Energy Crisis.

### 7.ENERGY MANAGEMENT .. Answer key

- TB Page 150
  - Coal
  - peat,lignite,anthracite,bituminous coal
  - ammonia,coal gas,coal tar,coke
- LPG
  - Ethyl mercaptan is added as indicator to detect gas leakage.
  - This cylinder has maturity period upto December 2022.
  - When LPG becomes gas ,the container can not accommodate the entire gas.This increases the pressure to a very high level causing a huge explosion.
  - Examine the rubber tube at regular intervals and ensure that it does not have a leakage,turn on the knob of stove only after the regulator is turned on.
  - TB Page 153
- Coal
  - methane
- LNG

b) LNG is liquefied natural gas. It can again be converted to gaseous form at atmospheric temperature and distributed through pipe lines.

5.a) TB Page 165

b) TB Page 166

c) Cause environmental problems including global warming.

d) Green Energy – solar cell, hydro electric power

Brown energy – Atomic Reactor, Diesel engine

6.a) Energy crisis is the consequence of increasing demand but decreasing availability.

b) TB Page 167